



Glass Door Refrigerated Display Case

Features

- Alloy frame
- Cheap price
- Customize



Model	HJX-SL-RE-D1	HJX-SL-RE-D2	HJX-SL-RE-D3
Temperature	2-10°C (Support customization)		
Refrigerating Fluid	R290	R290	R290
Voltage (V)	220V/50HZ	220V/50HZ	220V/50HZ
Power (W)	130-180W	210W	310W
Size (L x W x H)	600*550*1960mm	1200*550*1960mm	1800*550*1960mm
Cooling type	Air Cooling/Direct cooling		
Temperature controller	Digital controller		
Glass door	Double Safety tempered glass Door		
Compressor location	Bottom	Bottom	Bottom
Capacity (L)	350L	700L	1000L
Loading (40HQ)(pcs)	97	47	32

Customization: product external structure color, light box and cabinet stickers, refrigeration method, number of shelves, caster size, built-in light color,Other accessories required.

Glass Door Refrigerated Display Case

Features

- Neat
- Sliding door



Model	TLX-SL-RE-D2	TLX-SL-RE-D3
Temperature	2-8°C (Support customization)	
Refrigerating Fluid	R134a	R134a
Voltage (V)	220V/50HZ	220V/50HZ
Power (W)	215W	310W
Size (L x W x H)	1200*600*2010	1800*550*2010
Cooling type	Air Cooling/Direct cooling	
Temperature controller	Digital controller	
Glass door	Double Safety tempered glass Door	
Compressor location	Bottom	Bottom
Capacity (L)	700L	1000L
Loading (40HQ)(pcs)	47	32

Customization: product external structure color, light box and cabinet stickers, refrigeration method, number of shelves, caster size, built-in light color,Other accessories required.

Glass Door Refrigerated Display Case

Features

- Neat
- Sliding door



Model	TLS-SL-RE-D2(660)	TLS-SL-RE-D2(800)	TLS-SL-RE-D3(1000)	TLS-SL-RE-D3(1200)
Temperature	2-8°C (Support customization)			
Refrigerating Fluid	R134a	R134a	R134a	R134a
Voltage (V)	220V/50HZ	220V/50HZ	220V/50HZ	220V/50HZ
Power (W)	180W	285W	350W	380W
Size (L x W x H)	1000*600*1920	1200*600*1920	1500*600*1920	1800*600*1920
Cooling type	Air Cooling/Direct cooling			
Temperature controller	Digital controller			
Glass door	Double Safety tempered glass Door			
Compressor location	Top	Top	Top	Top
Capacity (L)	660L	800L	1000L	1200L
Loading (40HQ)(pcs)	47	47	32	32

Customization: product external structure color, light box and cabinet stickers, refrigeration method, number of shelves, caster size, built-in light color, Other accessories required.

Glass Door Refrigerated Display Case

Features

- Ambient light
- Automatic Defrost
- Visual Impact



Model	TLB-SL-RE-D2(990)	TLB-SL-RE-D2(1070)	TLB-SL-RE-D3(1500)
Temperature	2-8°C (Support customization)		
Refrigerating Fluid	R134a	R134a	R134a
Compressors	2	3	4
Voltage (V)	220V/50HZ	220V/50HZ	220V/50HZ
Power (W)	350W	380	420W
Size (L x W x H)	1100*600*2010	1200*600*2010	1800*600*2010
Cooling type	Air Cooling/Direct cooling		
Temperature controller	Digital controller		
Glass door	Double Safety tempered glass Door		
Compressor location	Back	Back	Back
Capacity (L)	990L	1070L	1500L
Loading (40HQ)(pcs)	47	43	32

Customization: product external structure color, light box and cabinet stickers, refrigeration method, number of shelves, caster size, built-in light color, Other accessories required.

Glass Door Refrigerated Display Case

Features

- Alloy frame
- Top light box
- Automatic defrost



Model	WHB-SL-RE-D1	WHB-SL-RE-D2	WHB-SL-RE-D3	WHB-SL-RE-D4
Temperature	2-8°C (Support customization)			
Refrigerating Fluid	R134a	R134a	R134a	R134a
Voltage (V)	220V/50HZ	220V/50HZ	220V/50HZ	220V/50HZ
Power (W)	350W	400W	600W	800W
Size (L x W x H)	600*600*1980	1100*600*1980	1680*600*1980	2250*600*1980
Cooling type	Air Cooling			
Temperature controller	Digital controller			
Glass door	Double Safety tempered glass Door			
Compressor location	Back	Back	Back	Back
Capacity (L)	400L	700L	1000L	1400L
Loading (40HQ)(pcs)	96	47	32	20

Customization: product external structure color, light box and cabinet stickers,number of shelves, caster size, built-in light color,Other accessories required.

Glass Door Refrigerated Display Case

Features

- Ambient light
- Hot sale
- Automatic defrost



Model	Type	Size (L x W x H)	Temperature	Capacity (L)	Cooling type	Power(W)	Refrigerating Fluid	Loading (40HQ)(pcs)
FL-400D	Single door	600*600*2010	0-10 (°C)	460L	Air Cooling	180W	600A	100
FL-680D	Double door	1000*600*2010		810L		280W	R290	63
BL-800D		1100*600*2010		1000L		280W	R290	57
FL-800D		1200*600*2010		1000L		280W	R290	50
FL-1200D	Three doors	1680*600*2010		1400L		420W	R290	37
FL-1500D		1800*600*2010		1600L		420W	R290	35
FL-1600D	Four doors	2250*650*2010		2000L		840W	R290	28
BL-500	Single door	500*580*1830		330L		180W	600A	127
BL-1000	1000 Double door	1000*580*1830		720L		280W	R290	68
BL-1100	1100 Double door	1100*580*1830		800L		280W	R290	62
BL-1500	1500 Three doors	1500*580*1830		1100L		420W	R290	46
BL-1660	1660 Three doors	1660*580*1830		1220L		420W	R290	42
BL-2010	2010 Four doors	2010*580*1830		1500L		520W	R290	32
BL-2210	2210 Four doors	2210*580*1830		1650L		840W	R290	30

Glass Door Refrigerated Display Case

Features

- Large Capacity
- Luxury Type



Model	WHB-SL-RE-D1	WHB-SL-RE-D2	WHB-SL-RE-D3	WHB-SL-RE-D4
Temperature	2-8°C (Support customization)			
Refrigerating Fluid	R134a	R134a	R134a	R134a
Voltage (V)	220V/50HZ	220V/50HZ	220V/50HZ	220V/50HZ
Power (W)	230W	480W	960W	800W
Size (L x W x H)	600*600*2000	1100*600*2000	1800*600*2000	2200*600*2000
Cooling type	Air Cooling			
Temperature controller	Digital controller			
Glass door	Double Safety tempered glass Door			
Compressor location	TOP	TOP	TOP	TOP
Capacity (L)	400L	800L	1500L	1650L
Loading (40HQ)(pcs)	96	47	32	20

Customization: All alloy material. Support customized accessories, display stickers.

Glass Door Refrigerated Display Case

Features

- Energy saving
- Customize
- Gorgeous



Model	TLB-SL-RE-D2(990)	TLB-SL-RE-D2(1070)	TLB-SL-RE-D3(1500)
Temperature	2-8°C (Support customization)		
Refrigerating Fluid	R134a	R134a	R134a
Voltage (V)	220V/50HZ	220V/50HZ	220V/50HZ
Power (W)	120W	220	230W
Size (L x W x H)	600*600*1920	1200*600*1920	1800*600*1920
Cooling type	Air Cooling/Direct cooling		
Temperature controller	Digital controller		
Glass door	Double Safety tempered glass Door		
Compressor location	TOP	TOP	TOP
Capacity (L)	400L	8000L	1200L
Loading (40HQ)(pcs)	105	43	32

Customization: product external structure color, light box and cabinet stickers, refrigeration method, number of shelves, caster size, built-in light color, Other accessories required.

Glass Door Refrigerated Display Case

Features

- Space utilization
- Office Scene



Model	XX-SL-RE-D1 (150)	XX-SL-RE-D1 (260)	XX-SL-RE-D1 (320)	XX-SL-RE-D2 (500)
Temperature	2-8°C (Support customization)			
Refrigerating Fluid	R600A	R600A	R600A	R600A
Voltage (V)	220V/50HZ	220V/50HZ	220V/50HZ	220V/50HZ
Size (L x W x H)	500*535*1120	500*535*1572	600*565*1622	972*565*1632
Weight (KG)	36KG	49KG	58KG	85KG
Cooling type	Air Cooling			
Temperature controller	Digital controller			
Glass door	Double Safety tempered glass Door			
Compressor location	Bottom	Bottom	Bottom	Bottom
Capacity (L)	150L	260L	1000L	1400L
Loading (40HQ)(pcs)	2210	155	120	70

Customization: product external structure color, light box and cabinet stickers, refrigeration method, number of shelves, caster size, built-in light color, Other accessories required.

Glass Door Refrigerated Display Case



Model	MIN-SL-RE-D1	MIN-SL-RE-D2	MIN-SL-RE-D2 (S)	MIN-SL-RE-D3	MIN-SL-RE-D3 (S)
Temperature	0-10°C				
Refrigerating Fluid	R600A	R600A	R600A	R600A	R600A
Voltage (V)	220V/50HZ	220V/50HZ	220V/50HZ	220V/50HZ	220V/50HZ
Size (L x W x H)	500*535*835	900*535*835	900*535*835	1350*530*835	1350*530*835
Power (W)	155W	235W	235W	275W	275W
Cooling type	Air Cooling				
Temperature controller	Digital controller				
Glass door	Double Safety tempered glass Door				
Compressor location	Back	Back	Back	Back	Back
Capacity (L)	130L	208L	208L	328L	328L
Loading (40HQ)(pcs)	300	175	175	115	115

Flower Display Case

Flower Display Case



Model	SL-RE-F1-1200	SL-RE-F1-1500	SL-RE-F1-1800	SL-RE-F1-2000	SL-RE-F1-2400
Temperature	2-15(°C)				
Voltage (V)	220V	220V	220V	220V	220V
Size (L x W x H)	1200*800*2000	1500*800*2000	1800*800*2000	2000*800*2000	2400*800*2000
Function	Automatic defogging、Moisturizing				
Voltage (V)	350W	380W	380W	430W	480W
Capacity (L)	1000L	1200L	1500L	1700L	2000L
Cooling type	Air Cooling				
Loading (40HQ)(pcs)	30	22	20	18	16

Model	BC-VDX-B6	BC-VDX-B11	BC-VDX-B17	BC-VDX-180
Temperature	2-8(°C)			
Voltage (V)	220V	220V	220V	220V
Size (L x W x H)	620*600*1980	1100*600*1980	1680*600*1980	2240*600*1980
Function	Automatic defogging、Moisturizing			
Voltage (V)	240W	320W	410W	650W
Capacity (L)	400L	700L	1050L	1600L
Cooling type	Air Cooling			
Loading (40HQ)(pcs)	80	50	32	24

Customization:Border color and material. body color.Brand compressor

Customization:Border color and material. body color.Brand compressor

Combined Island Freezer

Free combination island cabinet can save the space of the store to the greatest extent

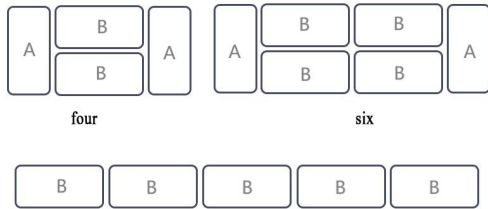
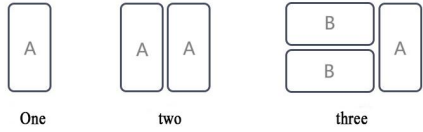

Combined Island Freezer

Free combination island cabinet can save the space of the store to the greatest extent

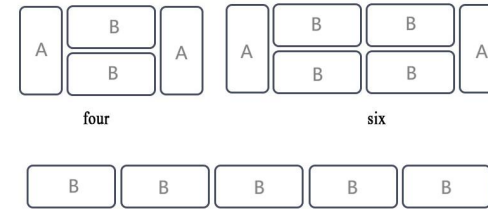
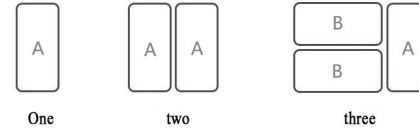

Model	ZHDG-ATOP	ZHDG-A15	ZHDG-A19	ZHDG-A21	ZHDG-A25
Temperature	-22-2(°C)				
Voltage (V)	220V	220V	220V	220V	220V
Size (L x W x H)	1850*850*795	1450*850*870	1850*850*870	2100*850*870	2500*850*870
Open with	Top Bottom Sliding Door				
Function	Direct cooling defrost(Customize)				
Cooling type	Direct cooling				
Loading (40HQ)(pcs)	55	70	55	48	40

Model	ZHDG-BTOP	ZHDG-B21	ZHDG-B25
Temperature	-18-22(°C)		
Voltage (V)	220V	220V	220V
Size (L x W x H)	1850*850*800	2100*850*800	2500*850*800
Open with	Left and Right Sliding Doors		
Function	Direct cooling defrost(Customize)		
Cooling type	Direct cooling		
Loading (40HQ)(pcs)	55	46	40

Combined Island Freezer

Free combination island cabinet can save the space of the store to the greatest extent

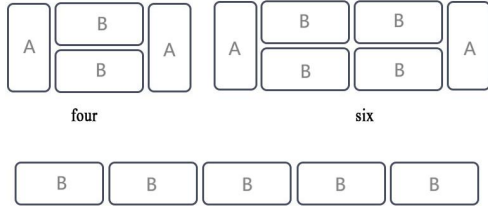
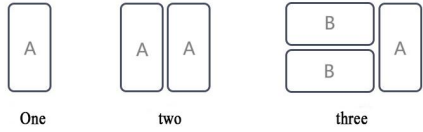

Combined Island Freezer

Free combination island cabinet can save the space of the store to the greatest extent

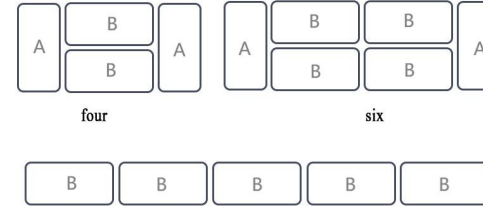
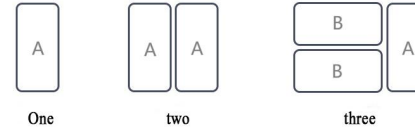
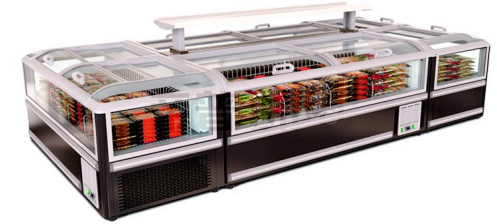

Model	ZHDG-CTOP	ZHDG-C15	ZHDG-C19	ZHDG-C21	ZHDG-C25
Temperature	-18-22(°C)				
Voltage (V)	220V	220V	220V	220V	220V
Size (L x W x H)	1900*850*890	1480*850*890	1880*850*890	2100*850*890	2500*850*890
Open with	Top Bottom Sliding Door/Left and Right Sliding Doors				
Function	Direct cooling defrost(Customize)				
Cooling type	Direct cooling				
Loading (40HQ)(pcs)	55	70	55	48	40

Model	ZHDG-BTOP	ZHDG-B21	ZHDG-B25
Temperature	-18-22(°C)		
Voltage (V)	220V	220V	220V
Size (L x W x H)	1850*850*800	2100*850*800	2500*850*800
Open with	Top Bottom Sliding Door		
Function	Direct cooling defrost(Customize)		
Cooling type	Direct cooling		
Loading (40HQ)(pcs)	55	46	40

Chest Freezer



Chest Freezer



Model	Size (L x W x H)	Internal size (LxWxH)	Capacity (L)	Power(W)	Number of compressors	DOOR
CF-W218	910*580*880	790*400*660	200	120W	1	1
CF-W398	1130*720*880	990*510*660	340	135W	1	1
CF-W498	1460*720*880	1340*510*660	460	170W	1	2
CF-W498-2	1460*720*880	1340*510*660	460	170W	2	2
CF-W598	1720*720*880	1580*510*660	540	210W	1	2
CF-W698	1950*720*880	1810*510*660	610	270W	1	2
CF-W798	1950*770*880	1810*560*660	670	270W	1	2
CF-W898	1980*830*880	1840*620*660	760	360W	1	2
CF-W998	2160*880*880	2020*680*660	900	360W	1	2
CF-W1288	2500*880*880	2360*680*660	1060	430W	1	2
CF-W1388-2	2600*1020*880	2460*820*660	1350	600W	2	3
CF-W1488-2	3100*960*880	2960*820*660	1600	600W	2	3
CF-W1588-2	3600*1100*900	3460*960*760	2200	600W	2	3

Model	Size (L x W x H)	Internal size (LxWxH)	Capacity (L)	Power(W)	Number of compressors	DOOR
CF-H218	910*580*880	790*400*660	200	120W	1	1
CF-H398	1130*720*880	990*510*660	340	135W	1	1
CF-H498	1460*720*880	1340*510*660	460	170W	1	2
CF-H498-2	1460*720*880	1340*510*660	460	170W	2	2
CF-H598	1720*720*880	1580*510*660	540	210W	1	2
CF-H698	1950*720*880	1810*510*660	610	270W	1	2
CF-H798	1950*770*880	1810*560*660	670	270W	1	2
CF-H898	1980*830*880	1840*620*660	760	360W	1	2
CF-H998	2160*880*880	2020*680*660	900	360W	1	2
CF-H1288	2500*880*880	2360*680*660	1060	430W	1	2

Supermarket Freezer



Model	SD/SC-1500H	SD/SC-1800H	SD/SC-2000H	SD/SC-2500H
Temperature	-30-0 (°C)			
Voltage (V)	220V	220V	220V	220V
Size (L x W x H)	1500*760*860	1800*760*860	2000*760*860	2500*760*840
Power(W)	300W	320W	340W	400W
Glass door	Double Safety tempered glass Door			
Weight (KG)	72KG	82KG	92KG	108KG
Capacity (L)	550L	668L	750L	1000L
Loading (40HQ)(pcs)	75	60	55	40

Customization: Appearance, stickers, materials, colors, inner liner, LOGO.

Supermarket Freezer



Model	Size (L x W x H)	Temperature	Capacity (L)	Power(W)	Loading (40HQ)(pcs)
SD/SC-1200S	1200*670*880	2-8/0-6 (°C)	350L	200W	105
SD/SC-1400S	1400*670*880		370L	230W	90
SD/SC-1600S	1600*800*880		613L	350W	78
SD/SC-1800S	1830*800*880		713L	400w	70
SD/SC-2000S	2000*800*880		780L	480w	50
SD/SC-2100S	2100*1000*880		1089L	550W	40
SD/SC-2500S	2500*1000*880		1315L	700W	32

Customization: Appearance, stickers, materials, colors, inner liner, LOGO.

Supermarket Freezer



Features

- Alloy frame
- Cheap price
- Customize

Supermarket Display Cases



Model	Size (L x W x H)	Temperature	Capacity (L)	Power(W)	Loading (40HQ)(pcs)
SD/SC-1200	1220*670*840	2-8/0-6 (°C)	216L	200W	85
SD/SC-1400	1400*670*840		260L	200W	78
SD/SC-1600	1600*800*840		385L	240W	67
SD/SC-1800	1830*800*840		440L	270W	60
SD/SC-2000	2000*800*840		491L	400W	53
SD/SC-2000A	2000*970*840		491L	400W	43
SD/SC-2200	2200*970*840		557L	400W	38
SD/SC-2500	2500*1000*850		820L	540W	34

Model	Size (L x W x H)	Temperature	Power(W)	Compressor location	Loading (40HQ)(pcs)
SL-SC-FM-12-YH	1200*1000*2000mm	2-8 (°C)	1000W	Bottom	28
SL-SC-FM-15-YH	1500*1000*2000mm		1000W		24
SL-SC-FM-18-YH	1800*1000*2000mm		1000W		20
SL-SC-FM-20-YH	2000*1000*2000mm		1000W		18
SL-SC-FM-25-YH	2500*1000*2000mm		2000W		14
SL-SC-FM-30-YH	3000*1000*2000mm		2300W		10

Customization: Appearance, stickers, materials, colors, inner liner, LOGO.

Customization: product external structure color,caster size, built-in light color,Other accessories required.

Supermarket Display Cases

Features

- Alloy frame
- Customize
- Gorgeous



Model	Size (L x W x H)	Temperature	Power(W)	Compressor location	Loading (40HQ)(pcs)
SL-SC-FM-12-XJ	1200*1000*2000mm	2-8 (°C)	1000W	Bottom	28
SL-SC-FM-15-XJ	1500*1000*2000mm		1000W		24
SL-SC-FM-18-XJ	1800*1000*2000mm		1000W		20
SL-SC-FM-20-XJ	2000*1000*2000mm		1000W		18
SL-SC-FM-25-XJ	2500*1000*2000mm		2000W		14
SL-SC-FM-30-XJ	3000*1000*2000mm		2300W		10
SL-SC-FM-35-XJ	3500*1000*2000mm		2500W		8
SL-SC-FM-40-XJ	4000*1000*2000mm		3000W		6

Customization: product external structure color, caster size, built-in light color,Other accessories required.

Supermarket Display Cases

Features

- Brand Compressor
- Artistic



Model	Size (L x W x H)	Temperature	Power(W)	Compressor location	Loading (40HQ)(pcs)
SL-SC-FM-12-XN	1200*800*2000mm	0-6 (°C)	1000W	Bottom	28
SL-SC-FM-15-XN	1500*800*2000mm		1000W		24
SL-SC-FM-18-XN	1800*800*2000mm		1000W		20
SL-SC-FM-20-XN	2000*800*2000mm		1000W		18
SL-SC-FM-25-XN	2500*800*2000mm		2000W		14
SL-SC-FM-30-XN	3000*800*2000mm		2300W		10
SL-SC-FM-35-XN	3500*800*2000mm		2500W		8
SL-SC-FM-40-XN	4000*800*2000mm		3000W		6

Customization: product external structure,number of shelves, caster size, built-in light color,Other accessories required.

Supermarket Display Cases

Features

- Sliding door
- Temperature



Model	Size (L x W x H)	Temperature	Power(W)	Compressor location	Loading (40HQ)(pcs)
SL-SC-FM-12-TL	1200*1000*2000mm	2-8/0-6 (°C)	1000W	Bottom	28
SL-SC-FM-15-TL	1500*1000*2000mm		1000W		24
SL-SC-FM-18-TL	1800*1000*2000mm		1000W		20
SL-SC-FM-20-TL	2000*1000*2000mm		1000W		18
SL-SC-FM-25-TL	2500*1000*2000mm		2000W		14
SL-SC-FM-30-TL	3000*1000*2000mm		2300W		10
SL-SC-FM-35-TL	3500*1000*2000mm		2500W		8

Customization: product external structure color,temperaturecaster,size, built-in light color,Other accessories required.

Supermarket Combined Cabinet

Features

- Alloy frame
- Cheap price
- Customize



Composition	Upper fuselage	Lower fuselage	Loading (40HQ)(pcs)
Function	Freezing/Refrigeration	Freezing/Refrigeration	
Temperature	0-10°C (Support customization)	-25-10°C (Support customization)	
Defogging technique	√ (Standard configuration)	√ (Standard configuration)	
Refrigerating Fluid	R290、R134a	R290、R134a	
Voltage (V)	220V 50HZ (Support customization)	220V 50HZ (Support customization)	
SL-SC-ZHG-08	800*860*1980mm		52
SL-SC-ZHG-10	1000*860*1980mm		42
SL-SC-ZHG-12	1200*860*1980mm		34
SL-SC-ZHG-14	1400*860*1980mm		30
SL-SC-ZHG-16	1600*860*1980mm		26
SL-SC-ZHG-18	1800*860*1980mm		22
SL-SC-ZHG-20	2000*860*1980mm		18
Cooling type	Air Cooling	Air Cooling/Direct cooling	
Compressor	1	1	
LED Display	White (Support customization)	White (Support customization)	
Compressor position	Bottom	Bottom	

Cake Display Case

Features

- Defogging
- Mirror Glass



Model	BC-TGDWBK-70	BC-TGDWBK-90	BC-TGDWBK-120
Temperature	2-8 (°C)		
Voltage (V)	220V	220V	220V
Size (L x W x H)	700*500*750	900*500*750	1200*500*750
Voltage (V)	200W	200W	210W
Loading (40HQ)(pcs)	260	210	150

Features

- Defogging
- Mirror Glass
- White Glass



Model	BC-TGDQJ-70	BC-TGDQJ-90	BC-TGDQJ-120
Temperature	2-8 (°C)		
Voltage (V)	220V	220V	220V
Size (L x W x H)	700*500*750	900*500*750	1200*500*750
Voltage (V)	200W	200W	210W
Loading (40HQ)(pcs)	260	210	150

Cake Display Case

Features

- Color ● ○
- Classic



Model	BC-TJDYH-90	BC-TJDYH-120
Temperature	2-8(°C)	
Voltage (V)	220V	220V
Size (L x W x H)	900*500*780	1200*500*780
Voltage (V)	200W	210W
Weight (KG)	83KG	97KG
Loading (40HQ)(pcs)	200	140



Model	BC-TJDZJ-90	BC-TJDZJ-120
Temperature	2-8(°C)	
Voltage (V)	220V	220V
Size (L x W x H)	900*500*780	1200*500*780
Voltage (V)	200W	210W
Weight (KG)	84KG	100KG
Loading (40HQ)(pcs)	200	140

Features

- Color ● ○
- Open Front Door



Model	BC-TJDQYH-90	BC-TJDQYH-120
Temperature	2-8(°C)	
Voltage (V)	220V	220V
Size (L x W x H)	900*500*780	1200*500*780
Voltage (V)	200W	210W
Weight (KG)	83KG	97KG
Loading (40HQ)(pcs)	200	140



Model	BC-TJDQZJ-90	BC-TJDQZJ-120
Temperature	2-8(°C)	
Voltage (V)	220V	220V
Size (L x W x H)	900*500*780	1200*500*780
Voltage (V)	200W	210W
Weight (KG)	84KG	100KG
Loading (40HQ)(pcs)	200	140

Cake Display Case

Features

- Color ● ○
- Defogging



Model	Temperature	Size (L x W x H)	Power(W)	Weight (KG)	Loading (40HQ)(pcs)
BC-TSSZJ-120	2-8(°C)	1200*410*450	295W	65KG	190
BC-TSSZJ-150		1500*410*450	305W	75KG	156
BC-TSSZJ-180		1800*410*450	315W	85KG	138
BC-TSSZJ-120H		1200*410*550	295W	65KG	190
BC-TSSZJ-150H		1500*410*550	305W	75KG	156
BC-TSSZJ-180H		1800*410*550	315W	85KG	138

Features

- Color ● ○
- Defogging



Model	Temperature	Size (L x W x H)	Power(W)	Weight (KG)	Loading (40HQ)(pcs)
BC-TSSZJ-120	2-8(°C)	1200*410*450	295W	57KG	190
BC-TSSZJ-150		1500*410*450	305W	67KG	156
BC-TSSZJ-180		1800*410*450	315W	77KG	138
BC-TSSZJ-120H		1200*410*550	295W	65KG	190
BC-TSSZJ-150H		1500*410*550	305W	75KG	156
BC-TSSZJ-180H		1800*410*550	315W	85KG	138

Cake Display Case

Features

- Color ● ○
- Classic



Model	BC-TJDYH-90	BC-TJDYH-120
Temperature	2-8(°C)	
Voltage (V)	220V	220V
Size (L x W x H)	900*500*780	1200*500*780
Voltage (V)	200W	210W
Weight (KG)	83KG	97KG
Loading (40HQ)(pcs)	200	140



Model	BC-TJDZJ-90	BC-TJDZJ-120
Temperature	2-8(°C)	
Voltage (V)	220V	220V
Size (L x W x H)	900*500*780	1200*500*780
Voltage (V)	200W	210W
Weight (KG)	84KG	100KG
Loading (40HQ)(pcs)	200	140

Features

- Color ● ○
- Open Front Door



Model	BC-TJDQYH-90	BC-TJDQYH-120
Temperature	2-8(°C)	
Voltage (V)	220V	220V
Size (L x W x H)	900*500*780	1200*500*780
Voltage (V)	200W	210W
Weight (KG)	83KG	97KG
Loading (40HQ)(pcs)	200	140



Model	BC-TJDQZJ-90	BC-TJDQZJ-120
Temperature	2-8(°C)	
Voltage (V)	220V	220V
Size (L x W x H)	900*500*780	1200*500*780
Voltage (V)	200W	210W
Weight (KG)	84KG	100KG
Loading (40HQ)(pcs)	200	140

Cake Display Case



Model	BC-VBZ-90	BC-VBZ-120	BC-VBZ-150	BC-VBZ-180	BC-VBZ-200
Temperature	2-8(°C)				
Voltage (V)	220V	220V	220V	220V	220V
Size (L x W x H)	900*660*1200	1200*660*1200	1500*660*1200	1800*660*1200	2000*660*1200
Voltage (V)	450W	480W	550W	630W	630W
Loading (40HQ)(pcs)	80	62	52	44	38



Model	BC-VHH-90	BC-VHH-120	BC-VHH-150	BC-VHH-180	BC-VHH-200
Temperature	2-8(°C)				
Voltage (V)	220V	220V	220V	220V	220V
Size (L x W x H)	900*660*1200	1200*660*1200	1500*660*1200	1800*660*1200	2000*660*1200
Voltage (V)	450W	480W	550W	630W	630W
Loading (40HQ)(pcs)	80	62	52	44	38

Customization: Compressor, color, LOGO, material

Cake Display Case

Features

- Various Specifications
- Customized Borders



Model	BC-VYC-90	BC-VYC-120	BC-VYC-150	BC-VYC-180	BC-VYC-200
Temperature	2-8(°C)				
Voltage (V)	220V	220V	220V	220V	220V
Size (L x W x H)	900*650*1100	1200*650*1100	1500*650*1100	1800*650*1100	2000*650*1100
Voltage (V)	450W	480W	550W	630W	630W
Loading (40HQ)(pcs)	82	65	54	46	40
Weight (KG)	83KG	97KG	84KG	100KG	100KG

Drawer style



Hidden style



Ordinary style



Customization: Border color and material. body color. Brand compressor

Cake Display Case



Model	BC-VDX-90	BC-VDX-120	BC-VDX-150	BC-VDX-180
Temperature	2-8(°C)			
Voltage (V)	220V	220V	220V	220V
Size (L x W x H)	700*900*1800	1200*900*1800	1500*900*1800	1800*900*1800
Voltage (V)	450W	480W	550W	630W
Loading (40HQ)(pcs)	56	30	24	20
Weight (KG)	83KG	97KG	84KG	100KG

Customization: Border color and material. body color. Brand compressor

Hanging Meat Case

Features

- Economy
- Thickening
- Space Utilization



Model	SL-GR-JJ-D6	SL-GR-JJ-D12	SL-GR-JJ-D18
Temperature	-15-5(°C)		
Voltage (V)	220V	220V	220V
Size (L x W x H)	600*700*1920	1200*700*1920	1680*700*1980
Number of compressors	1	1	2
Voltage (V)	240W	380W	600W
Bear Weight(KG)	100KG	150KG	450KG
Cooling type	Direct cooling		
Glass door Double	Safety tempered glass Door		
Compressor location	TOP	TOP	TOP
Loading (40HQ)(pcs)	66	40	26

Customization: Customized length and load-bearing according to usage, various sizes

Hanging Meat Case

Features

- Economy
- Thickening
- Space Utilization



Model	SL-GR-BZ-D6	SL-GR-BZ-D12	SL-GR-BZ-D18
Temperature	-20-10(°C)		
Voltage (V)	220V	220V	220V
Size (L x W x H)	600*700*1950	1200*700*1950	1800*700*1950
Number of compressors	1	1	2
Voltage (V)	290W	492W	600W
Bear Weight(KG)	100KG	150KG	450KG
Cooling type	Direct cooling		
Glass door Double	Safety tempered glass Door		
Compressor location	TOP	TOP	TOP
Loading (40HQ)(pcs)	66	40	22

Customization: Customized length and load-bearing according to usage, various sizes

Meat & Deli Display Cabinets

Features

- Multifunctional
- Alloy
- Custom made



Model	Temperature	Size (L x W x H)	Cooling type	Power(W)	Capacity (L)	Loading (40HQ)(pcs)
MDDC-HBHJ-12	2-8(°C)	1200*1050*900	Air Cooling/ Direct cooling	385W	218L	50
MDDC-HBHJ-15		1500*1050*900		495W	276L	40
MDDC-HBHJ-18		1800*1050*900		505W	334L	34
MDDC-HBHJ-20		2000*1050*900		505W	373L	30
MDDC-HBHJ-25		2500*1050*900		595W	471L	24
MDDC-HBHJ-30		3000*1050*900		595W	568L	20

Features

- Multifunctional
- Standard style
- Custom made



Model	Temperature	Size (L x W x H)	Cooling type	Power(W)	Capacity (L)	Loading (40HQ)(pcs)
MDDC-HBZB-12	2-8(°C)	1200*1050*890	Air Cooling/ Direct cooling	385W	218L	50
MDDC-HBZB-15		1500*1050*890		495W	276L	40
MDDC-HBZB-18		1800*1050*890		505W	334L	34
MDDC-HBZB-20		2000*1050*890		505W	373L	30
MDDC-HBZB-25		2500*1050*890		595W	471L	24
MDDC-HBZB-30		3000*1050*890		595W	568L	20

Meat & Deli Display Cabinets

Features

- Multifunctional
- Color Matching
- Deli Display



Model	Temperature	Size (L x W x H)	Cooling type	Power(W)	Capacity (L)	Loading (40HQ)(pcs)
MDDC-SSYH-12	2-8(°C)	1200*1050*890	Air Cooling/ Direct cooling	385W	218L	50
MDDC-SSYH-15		1500*1050*890		495W	276L	40
MDDC-SSYH-18		1800*1050*890		505W	334L	34
MDDC-SSYH-20		2000*1050*890		505W	373L	30
MDDC-SSYH-25		2500*1050*890		595W	471L	24
MDDC-SSYH-30		3000*1050*890		595W	568L	20

Meat & Deli Display Cabinets

Features

- Multifunctional
- Alloy
- Custom made



Model	Temperature	Size (L x W x H)	Cooling type	Power(W)	Capacity (L)	Loading (40HQ)(pcs)
MDDC-RBZB-12	2-8(°C)	1200*1050*880	Air Cooling/ Direct cooling	385W	218L	50
MDDC-RBZB-15		1500*1050*880		495W	276L	40
MDDC-RBZB-18		1800*1050*880		505W	334L	34
MDDC-RBZB-20		2000*1050*880		505W	373L	30
MDDC-RBZB-25		2500*1050*880		595W	471L	24
MDDC-RBZB-30		3000*1050*880		595W	568L	20



Features

- Multifunctional
- Color Matching
- Energy Saving

Model	Temperature	Size (L x W x H)	Cooling type	Power(W)	Capacity (L)	Loading (40HQ)(pcs)
MDDC-HBJN-12	2-8(°C)	1200*1050*860	Air Cooling/ Direct cooling	175W	218L	50
MDDC-HBJN-15		1500*1050*860		175W	276L	40
MDDC-HBJN-18		1800*1050*860		220W	334L	34
MDDC-HBJN-20		2000*1050*860		235W	373L	30
MDDC-HBJN-25		2500*1050*860		270W	471L	24
MDDC-HBJN-30		3000*1050*860		350W	568L	20

Features

- No Door
- Standard style
- Custom made

Model	Temperature	Size (L x W x H)	Cooling type	Power(W)	Capacity (L)	Loading (40HQ)(pcs)
MDDC-CYWM-12	2-8(°C)	1200*1050*890	Air Cooling/ Direct cooling	385W	218L	50
MDDC-CYWM-15		1500*1050*890		495W	276L	40
MDDC-CYWM-18		1800*1050*890		505W	334L	34
MDDC-CYWM-20		2000*1050*890		505W	373L	30
MDDC-CYWM-25		2500*1050*890		595W	471L	24
MDDC-CYWM-30		3000*1050*890		595W	568L	20



Dry Aging Cabinets

Features

- Sterilization
- UV Rays
- Defogging



Model	GSSC-HB-D1	GSSC-HB-D2	GSSC-HB-D3
Temperature	-2-2(°C)		
Humidity	60%-85%		
Voltage (V)	220V	220V	220V
Size (L x W x H)	630*770*2050	1200*750*2150	1800*750*2150
Capacity (L)	540L	940L	1480L
Power(W)	880W	1280W	1580W
Bear Weight(KG)	110KG	180KG	230KG
Cooling type	Circulating Air Cooling		
Single layer load-bearing	35KG		
Function	Sterilization, UV Rays,Defogging		
Compressor location	Bottom	Bottom	Bottom
Loading (40HQ)(pcs)	64	32	20

Dry Aging Cabinets

Features

- Sterilization
- UV Rays
- Defogging



Model	GSSC-JS-D1	GSSC-JS-D2	GSSC-JS-D3
Temperature	-2-2(°C)		
Humidity	60%-85%		
Voltage (V)	220V	220V	220V
Size (L x W x H)	630*770*2050	1200*750*2150	1800*750*2150
Capacity (L)	540L	940L	1480L
Power(W)	880W	1280W	1580W
Bear Weight(KG)	110KG	180KG	230KG
Cooling type	Circulating Air Cooling		
Single layer load-bearing	35KG		
Function	Sterilization, UV Rays,Defogging		
Compressor location	Bottom	Bottom	Bottom
Loading (40HQ)(pcs)	64	32	20

Dry Aging Cabinets

Features

- Sterilization
- UV Rays
- Defogging



Model	GSSC-HH-D1	GSSC-HH-D2	GSSC-HH-D3
Temperature	-5-0(°C)		
Humidity	60%-85%		
Voltage (V)	220V	220V	220V
Size (L x W x H)	550*600*1985	1100*600*1985	1680*600*1985
Capacity (L)	420L	850L	1200L
Power(W)	600W	850W	1000W
Cooling type	Circulating Air Cooling		
Function	Sterilization, UV Rays,Defogging		
Compressor location	Bottom	Bottom	Bottom
Loading (40HQ)(pcs)	90	46	30

Customization: product external structure color, light box and cabinet stickers, number of shelves, caster size, built-in light color,Other accessories required.

Beer Dispenser



Model	PJS24
Size (L x W x H)	1000*650*(1000+650)
Voltage (V)	220V
Cooling type	Air Cooling
Splitter Head	2
Capacity	4*20L barrels
Temperature	0-8 (°C)
Loading (40HQ)(pcs)	114

Model	PJS44
Size (L x W x H)	1000*650*(1000+650)
Voltage (V)	220V
Cooling type	Air Cooling
Splitter Head	4
Capacity	4*20L barrels
Temperature	0-8 (°C)
Loading (40HQ)(pcs)	114



Model	PJS46
Size (L x W x H)	1250*680*(1000+620)
Voltage (V)	220V
Cooling type	Air Cooling
Splitter Head	4
Capacity	6*20L barrels
Temperature	0-8 (°C)
Loading (40HQ)(pcs)	80

Model	PJS68
Size (L x W x H)	1450*680*(1000+620)
Voltage (V)	220V
Cooling type	Air Cooling
Splitter Head	6
Capacity	8*20L barrels
Temperature	0-8 (°C)
Loading (40HQ)(pcs)	74



Beer Dispenser



Model	PJS810
Size (L x W x H)	1800*730*(1000+620)
Voltage (V)	220V
Cooling type	Air Cooling
Splitter Head	8
Capacity	10*20L barrels
Temperature	0-8 (°C)
Loading (40HQ)(pcs)	56

Model	PJS1012
Size (L x W x H)	2000*730*(1000+650)
Voltage (V)	220V
Cooling type	Air Cooling
Splitter Head	10
Capacity	12*20L barrels
Temperature	0-8 (°C)
Loading (40HQ)(pcs)	30



Model	PJS1014
Size (L x W x H)	2200*730*(1000+650)
Voltage (V)	220V
Cooling type	Air Cooling
Splitter Head	10
Capacity	14*20L barrels
Temperature	0-8 (°C)
Loading (40HQ)(pcs)	24

Model	PJB24
Size (L x W x H)	1000*650*(1000+620)
Voltage (V)	220V
Cooling type	Air Cooling
Splitter Head	2
Capacity	4*20L barrels
Temperature	0-8 (°C)
Loading (40HQ)(pcs)	110



Model	PJB46
Size (L x W x H)	1250*680*(1000+620)
Voltage (V)	220V
Cooling type	Air Cooling
Splitter Head	4
Capacity	6*20L barrels
Temperature	0-8 (°C)
Loading (40HQ)(pcs)	80



Model	PJS810
Size (L x W x H)	1800*730*(1000+620)
Voltage (V)	220V
Cooling type	Air Cooling
Splitter Head	8
Capacity	10*20L barrels
Temperature	0-8 (°C)
Loading (40HQ)(pcs)	56



Beer Dispenser

Model	PJB44
Size (L x W x H)	1000*650*(1000+650)
Voltage (V)	220V
Cooling type	Air Cooling
Splitter Head	4
Capacity	4*20L barrels
Temperature	0-8 (°C)
Loading (40HQ)(pcs)	114



Model	PJB68
Size (L x W x H)	1450*680*(1000+620)
Voltage (V)	220V
Cooling type	Air Cooling
Splitter Head	6
Capacity	8*20L barrels
Temperature	0-8 (°C)
Loading (40HQ)(pcs)	74

Beer Dispenser



Model	PJS810
Size (L x W x H)	2000*730*(1000+650)
Voltage (V)	220V
Cooling type	Air Cooling
Splitter Head	10
Capacity	12*20L barrels
Temperature	0-8 (°C)
Loading (40HQ)(pcs)	30

Model	PJS1012
Size (L x W x H)	2200*730*(1000+650)
Voltage (V)	220V
Cooling type	Air Cooling
Splitter Head	10
Capacity	14*20L barrels
Temperature	0-8 (°C)
Loading (40HQ)(pcs)	24



Features:

Thickened stainless steel, brand compressor, support customization, silent work, precise temperature control, whole machine foam, green energy saving, food grade 304 stainless steel faucet.

Ice Cream Machine



Model	D16A(Desktop)	D20B(Vertical)	D28B(Vertical)	D36B(Vertical)
Voltage	220V/50HZ 110V/60HZ	220V/50HZ 110V/60HZ	220V/50HZ 110V/60HZ	220V/50HZ
Power	1200W	1850W	2200W	2800W
Output	16-18L/H	20L/H	28L/H	36L/H
Capacity	3L*2	4L*2	6L*2	6L*2
Size1 (L x W x H)	400*530*760	600*500*1350mm	600*500*1350mm	720*580*1380mm
Temperature Controller	Digital controller	Digital controller	Digital controller	Digital controller
Refrigerating Fluid	R22	R22/410a	R22/410a	R22
Refrigerating Method	Air cooled	Air cooled	Air cooled	Air cooled
Weight	56KG	90KG	100KG	110KG
Loading (40HQ)(pcs)	280	124	124	110

BEST SELLING PRODUCTS

Professional
Products

Commercial Kitchen Equipment

- ODM&OEM
- Price advantage
- Fast delivery
- Manufacturer



Kitchen Refrigeration Freezer Case

Model	CFBX-LRD-460	CFBX-LFD-460	CFBX-LRFD-460
Power (W)	280W	280W	280W
Voltage (V)	220V	220V	220V
Size (L x W x H)	600*700*1930	600*700*1930	600*700*1930
Temperature	2-8(°C)	-5- (-15)(°C)	2-8(°C) /-5- (-15)(°C)
Capacity (L)	460L	460L	460L
Compressors	1	1	1
Cooling type	Air Cooling	Direct cooling	Air Cooling/ Direct cooling
Weight (KG)	75KG	75KG	75KG
Loading (40HQ)(pcs)	68	68	68



Model	CFBX-LRD-920	CFBX-LFD-920	CFBX-LRFD-920
Power (W)	112W/112W	112W/112W	112W/112W
Voltage (V)	220V	220V	220V
Size (L x W x H)	1200*700*1930	1200*700*1930	1200*700*1930
Temperature	2-8(°C)	-5- (-15)(°C)	2-8(°C) /-5- (-15)(°C)
Capacity (L)	920L	920L	920L
Compressors	2	2	2
Cooling type	Air Cooling	Direct cooling	Air Cooling/ Direct cooling
Weight (KG)	120KG	120KG	120KG
Loading (40HQ)(pcs)	40	40	40



Kitchen Refrigeration Freezer Case

Model	CFBX-LRD-1300	CFBX-LFD-1300	CFBX-LRFD-1300
Power (W)	250W/250W	250W/250W	250W/250W
Voltage (V)	220V	220V	220V
Size (L x W x H)	1800*700*1950	1800*700*1950	1800*700*1950
Temperature	2-8(°C)	-5- (-15)(°C)	2-8(°C) /-5- (-15)(°C)
Capacity (L)	1279L	1279L	1279L
Compressors	2	2	2
Cooling type	Air Cooling	Direct cooling	Air Cooling/ Direct cooling
Weight (KG)	170KG	170KG	170KG
Loading (40HQ)(pcs)	24	24	24



Model	FXBX-LRD-920	FXBX-LRD-920	FXBX-LRD-920
Power (W)	112W/112W	112W/112W	112W/112W
Voltage (V)	220V	220V	220V
Size (L x W x H)	1200*700*1930	1200*700*1930	1200*700*1930
Temperature	2-8(°C)	-5- (-15)(°C)	2-8(°C) /-5- (-15)(°C)
Capacity (L)	920L	920L	920L
Compressors	2	2	2
Cooling type	Air Cooling	Direct cooling	Air Cooling/ Direct cooling
Weight (KG)	120KG	120KG	120KG
Loading (40HQ)(pcs)	40	40	40



Kitchen Refrigeration Freezer Case



Model	BLM-LR2D-920	BLM-LR3D-1420	BLM-LR4D-920	BLM-LR6D-1390
Voltage (V)	220V	220V	220V	220V
Size (L x W x H)	1200*700*1970	1800*700*1970	1200*700*1930	1800*700*1930
Power	300W	390W	280W	390W
Temperature	2-8(°C)	2-8(°C)	2-8(°C)	2-8(°C)
Capacity (L)	920L	1420L	920L	1390L
Compressors	1	1	1	1
Cooling type	Air Cooling	Air Cooling	Air Cooling	Air Cooling
Weight (KG)	100KG	140KG	100KG	140KG
Loading (40HQ)(pcs)	40	24	40	24

Customization: Rapid cooling, microporous foam insulation, intelligent digital display screen, ultra-large capacity, energy saving and low power consumption.

Kitchen Refrigeration Freezer Case

Model	ZTCF-LRD-460	CFBX-LFD-460	CFBX-LRFD-460
Power (W)	280W	280W	280W
Voltage (V)	220V	220V	220V
Size (L x W x H)	600*700*1950	600*700*1950	600*700*1950
Temperature	2-8(°C)	-5- (-15)(°C)	2-8(°C) /-5- (-15)(°C)
Capacity (L)	460L	460L	460L
Compressors	1	1	1
Cooling type	Air Cooling	Direct cooling	Air Cooling/ Direct cooling
Weight (KG)	75KG	75KG	75KG
Loading (40HQ)(pcs)	68	68	68



Model	JBT-PT-R428	JBT-PT-L428	JBT-PT-RL428
Power (W)	280W	280W	280W
Voltage (V)	220V	220V	220V
Size (L x W x H)	600*700*1930	600*700*1930	600*700*1930
Temperature	2-8(°C)	-5- (-15)(°C)	2-8(°C) /-5- (-15)(°C)
Capacity (L)	428L	428L	428L
Compressors	1	1	1
Cooling type	Air Cooling	Direct cooling	Air Cooling/ Direct cooling
Weight (KG)	75KG	75KG	75KG
Loading (40HQ)(pcs)	68	68	68



Model	ZTCF-LRD-920	ZTCF-LFD-920	ZTCF-LRFD-920
Power (W)	112W/112W	112W/112W	112W/112W
Voltage (V)	220V	220V	220V
Size (L x W x H)	1200*700*1950	1200*700*1950	1200*700*1950
Temperature	2-8(°C)	-5- (-15)(°C)	2-8(°C) /-5- (-15)(°C)
Capacity (L)	920L	920L	920L
Compressors	2	2	2
Cooling type	Air Cooling	Direct cooling	Air Cooling/ Direct cooling
Weight (KG)	120KG	120KG	120KG
Loading (40HQ)(pcs)	40	40	40



Model	JBT-2PT-R1050	JBT-2PT-L1050	JBT-2PT-RL1050
Power (W)	112W/112W	112W/112W	112W/112W
Voltage (V)	220V	220V	220V
Size (L x W x H)	1200*700*1950	1200*700*1950	1200*700*1950
Temperature	2-8(°C)	-5- (-15)(°C)	2-8(°C) /-5- (-15)(°C)
Capacity (L)	1050L	1050L	1050L
Compressors	2	2	2
Cooling type	Air Cooling	Direct cooling	Air Cooling/ Direct cooling
Weight (KG)	120KG	120KG	120KG
Loading (40HQ)(pcs)	40	40	40



Kitchen Refrigeration Freezer Case

Refrigerated Workbench

Model	JBT-2PT-R1014	JBT-2PT-L1014	JBT-2PT-RL1014
Power (W)	112W/112W	112W/112W	112W/112W
Voltage (V)	220V	220V	220V
Size (L x W x H)	1220*750*1995	1220*750*1995	1220*750*1995
Temperature	2-8(°C)	-5- (-15)(°C)	2-8(°C) /-5- (-15)(°C)
Capacity (L)	1014L	1014L	1014L
Compressors	2	2	2
Cooling type	Air Cooling	Direct cooling	Air Cooling/ Direct cooling
Weight (KG)	120KG	120KG	120KG
Loading (40HQ)(pcs)	40	40	40



Features

- Door Springback
- CNC Panel



Model	JBT-PT-R1567	JBT-PT-L1567	JBT-PT-rL1567
Power (W)	426W	426W	426W
Voltage (V)	220V	220V	220V
Size (L x W x H)	1800*700*1950	1800*700*1950	1800*700*1950
Temperature	2-8(°C)	-5- (-15)(°C)	2-8(°C) /-5- (-15)(°C)
Capacity (L)	1567L	1567L	1567L
Compressors	2	2	2
Cooling type	Air Cooling	Direct cooling	Air Cooling/ Direct cooling
Weight (KG)	210KG	210KG	210KG
Loading (40HQ)(pcs)	24	24	24



Model	Temperature	Size (L x W x H)	Voltage (V)	Loading (40HQ)(pcs)
LCGZT-HH-R1268	2-8 (°C)	1200*600*800	220V	92
LCGZT-HH-R1288		1200*800*800		80
LCGZT-HH-R1568		1500*600*800		78
LCGZT-HH-R1588		1500*800*800		60
LCGZT-HH-R1868		1800*600*800		62
LCGZT-HH-R1888		1800*800*800		50
LCGZT-HH-R2068		2000*600*800		56
LCGZT-HH-R2088		2000*800*800		44
LCGZT-HH-F1268	-15-0 (°C)	1200*600*800		92
LCGZT-HH-F1288		1200*800*800		80
LCGZT-HH-F1568		1500*600*800		78
LCGZT-HH-F1588		1500*800*800		60
LCGZT-HH-F1868		1800*600*800		62
LCGZT-HH-F1888		1800*800*800		50
LCGZT-HH-F2068		2000*600*800		56
LCGZT-HH-F2088		2000*800*800		44

Refrigerated Workbench

Features

- Custom Materials
- Metal Shelves



Features

- Door Springback
- CNC Panel



Model	Temperature	Size (L x W x H)	Voltage (V)	Loading (40HQ)(pcs)
LCGZT-BZ-R1268	2-8 (°C)	1200*600*800	220V	92
LCGZT-BZ-R1288		1200*800*800		80
LCGZT-BZ-R1568		1500*600*800		78
LCGZT-BZ-R1588		1500*800*800		60
LCGZT-BZ-R1868		1800*600*800		62
LCGZT-BZ-R1888		1800*800*800		50
LCGZT-BZ-R2068		2000*600*800		56
LCGZT-BZ-R2088		2000*800*800		44
LCGZT-BZ-F1268	-15-0 (°C)	1200*600*800	220V	92
LCGZT-BZ-F1288		1200*800*800		80
LCGZT-BZ-F1568		1500*600*800		78
LCGZT-BZ-F1588		1500*800*800		60
LCGZT-BZ-F1868		1800*600*800		62
LCGZT-BZ-F1888		1800*800*800		50
LCGZT-BZ-F2068		2000*600*800		56
LCGZT-BZ-F2088		2000*800*800		44

Model	Temperature	Size (L x W x H)	Voltage (V)	Loading (40HQ)(pcs)
LCGZT-PT-R1268	2-8 (°C)	1200*600*800	220V	92
LCGZT-PT-R1288		1200*800*800		80
LCGZT-PT-R1568		1500*600*800		78
LCGZT-PT-R1588		1500*800*800		60
LCGZT-PT-R1868		1800*600*800		62
LCGZT-PT-R1888		1800*800*800		50
LCGZT-PT-R2068		2000*600*800		56
LCGZT-PT-R2088		2000*800*800		44
LCGZT-PT-F1268	-15-0 (°C)	1200*600*800	220V	92
LCGZT-PT-F1288		1200*800*800		80
LCGZT-PT-F1568		1500*600*800		78
LCGZT-PT-F1588		1500*800*800		60
LCGZT-PT-F1868		1800*600*800		62
LCGZT-PT-F1888		1800*800*800		50
LCGZT-PT-F2068		2000*600*800		56
LCGZT-PT-F2088		2000*800*800		44

Refrigerated Workbench

Features

- Layered
- Spliced Liner



Model	Temperature	Size (L x W x H)	Voltage (V)	Loading (40HQ)(pcs)
LCGZT-CJ-R1288	2-8 (°C)	1200*800*800	220V	80
LCGZT-CJ-R1588		1500*800*800		60
LCGZT-CJ-R1888		1800*800*800		50
LCGZT-CJ-R2088		2000*800*800		44
LCGZT-CJ-R1288	-15-0 (°C)	1200*800*800		80
LCGZT-CJ-R1588		1500*800*800		60
LCGZT-CJ-R1888		1800*800*800		50
LCGZT-CJ-R2088		2000*800*800		44
LCGZT-CJ-LD1288	-25-0 (°C)	1200*800*800		80
LCGZT-CJ-LD1588		1500*800*800		60
LCGZT-CJ-LD1888		1800*800*800		50
LCGZT-CJ-LD2088		2000*800*800		44

Refrigerated Workbench

Features

- 10CM baffle
- Layered



Model	Temperature	Size (L x W x H)	Voltage (V)	Loading (40HQ)(pcs)
LCGZT-KB-R1268	2-8 (°C)	1200*600*800	220V	92
LCGZT-KB-R1288		1200*800*800		80
LCGZT-KB-R1568		1500*600*800		78
LCGZT-KB-R1588		1500*800*800		60
LCGZT-KB-R1868		1800*600*800		62
LCGZT-KB-R1888		1800*800*800		50
LCGZT-KB-R2068		2000*600*800		56
LCGZT-KB-R2088		2000*800*800		44
LCGZT-KB-F1268	-15-0 (°C)	1200*600*800		92
LCGZT-KB-F1288		1200*800*800		80
LCGZT-KB-F1568		1500*600*800		78
LCGZT-KB-F1588		1500*800*800		60
LCGZT-KB-F1868		1800*600*800		62
LCGZT-KB-F1888		1800*800*800		50
LCGZT-KB-F2068		2000*600*800		56
LCGZT-KB-F2088		2000*800*800		44

Refrigerated Workbench

Features

- Glass Door
- Metal Shelves



Features

- Universal Wheel
- Layered



Refrigerated Workbench

Model	Temperature	Size (L x W x H)	Voltage (V)	Loading (40HQ)(pcs)	
LCGZT-GD-R1268	2-8 (°C)	1200*600*800	220V	92	
LCGZT-GD-R1288		1200*800*800		80	
LCGZT-GD-R1568		1500*600*800		78	
LCGZT-GD-R1588		1500*800*800		60	
LCGZT-GD-R1868		1800*600*800		62	
LCGZT-GD-R1888		1800*800*800		50	
LCGZT-GD-R2068		2000*600*800		56	
LCGZT-GD-R2088		2000*800*800		44	
LCGZT-GD-F1268		-15-0 (°C)		1200*600*800	92
LCGZT-GD-F1288				1200*800*800	80
LCGZT-GD-F1568	1500*600*800		78		
LCGZT-GD-F1588	1500*800*800		60		
LCGZT-GD-F1868	1800*600*800		62		
LCGZT-GD-F1888	1800*800*800		50		
LCGZT-GD-F2068	2000*600*800		56		
LCGZT-GD-F2088	2000*800*800		44		

Model	Temperature	Size (L x W x H)	Voltage (V)	Loading (40HQ)(pcs)	
LCGZT-LZ-R1268	2-8 (°C)	1200*600*800	220V	92	
LCGZT-LZ-R1288		1200*800*800		80	
LCGZT-LZ-R1568		1500*600*800		78	
LCGZT-LZ-R1588		1500*800*800		60	
LCGZT-LZ-R1868		1800*600*800		62	
LCGZT-LZ-R1888		1800*800*800		50	
LCGZT-LZ-R2068		2000*600*800		56	
LCGZT-LZ-R2088		2000*800*800		44	
LCGZT-LZ-F1268		-18-(-5) (°C)		1200*600*800	92
LCGZT-LZ-F1288				1200*800*800	80
LCGZT-LZ-F1568	1500*600*800		78		
LCGZT-LZ-F1588	1500*800*800		60		
LCGZT-LZ-F1868	1800*600*800		62		
LCGZT-LZ-F1888	1800*800*800		50		
LCGZT-LZ-F2068	2000*600*800		56		
LCGZT-LZ-F2088	2000*800*800		44		

Features

- Metal Shelves
- Layered



Model	SL-TSLT-70
Temperature	2-8 (°C)
Power (W)	166W
Voltage (V)	220V
Size (L x W x H)	720*395*225
Capacity (L)	37L
Loading (40HQ)(pcs)	700

Model	Temperature	Size (L x W x H)	Voltage (V)	Loading (40HQ)(pcs)
LCSLT-CG-R1288	2-8 (°C)	1200*800*800	220V	80
LCSLT-CG-R1588		1500*800*800		60
LCSLT-CG-R1888		1800*800*800		50
LCGZT-CG-R1288	-15-0 (°C)	1200*800*800		80
LCGZT-CG-R1588		1500*800*800		60
LCGZT-CG-R1888		1800*800*800		50
LCGZT-CG-LD1288	2-8 (°C)	1200*800*800		80
LCGZT-CG-LD1588		1500*800*800		60
LCGZT-CG-LD1888	/-15-0 (°C)	1800*800*800		50

Model	SL-TSLT-80
Temperature	2-8 (°C)
Power (W)	166W
Voltage (V)	220V
Size (L x W x H)	800*395*225
Capacity (L)	38L
Loading (40HQ)(pcs)	620



Salad Preparation Workbench

Salad Preparation Workbench



Model	SL-TSLT-90
Temperature	2-8 (°C)
Power (W)	166W
Voltage (V)	220V
Size (L x W x H)	720*395*225
Capacity (L)	40L
Loading (40HQ)(pcs)	562



Model	SL-TSLT-110
Temperature	2-8 (°C)
Power (W)	166W
Voltage (V)	220V
Size (L x W x H)	1100*395*225
Capacity (L)	40L
Loading (40HQ)(pcs)	470



Model	SL-TSLT-100
Temperature	2-8 (°C)
Power (W)	166W
Voltage (V)	220V
Size (L x W x H)	1000*395*225
Capacity (L)	40L
Loading (40HQ)(pcs)	510



Model	SL-TSLT-120
Temperature	2-8 (°C)
Power (W)	166W
Voltage (V)	220V
Size (L x W x H)	1200*395*225
Capacity (L)	41L
Loading (40HQ)(pcs)	440



Salad Preparation Workbench

Salad Preparation Workbench



Model	SL-TSLT-140
Temperature	2-8 (°C)
Power (W)	172W
Voltage (V)	220V
Size (L x W x H)	1400*395*225
Capacity (L)	50L
Loading (40HQ)(pcs)	390



Model	SL-TSLT-160
Temperature	2-8 (°C)
Power (W)	172W
Voltage (V)	220V
Size (L x W x H)	1600*395*225
Capacity (L)	60L
Loading (40HQ)(pcs)	320



Model	SL-TSLT-150
Temperature	2-8 (°C)
Power (W)	174W
Voltage (V)	220V
Size (L x W x H)	1200*395*225
Capacity (L)	55L
Loading (40HQ)(pcs)	340



Model	SL-TSLT-180
Temperature	2-8 (°C)
Power (W)	180W
Voltage (V)	220V
Size (L x W x H)	1800*395*225
Capacity (L)	70L
Loading (40HQ)(pcs)	300



Salad Preparation Workbench

Features

- Metal Frame
- Fold



Model	Temperature	Size (L x W x H)	Voltage (V)	Loading (40HQ)(pcs)
LCSLT-GD-R1268	2-8 (°C)	1200*600*800/600	220V	92
LCSLT-GD-R1288		1200*800*800/600		80
LCSLT-GD-R1568		1500*600*800/600		78
LCSLT-GD-R1588		1500*800*800/600		60
LCSLT-GD-R1868		1800*600*800/600		62
LCSLT-GD-R1888		1800*800*800/600		50
LCSLT-GD-F1268		-18-(-5) (°C)		1200*600*800/600
LCSLT-GD-F1288	1200*800*800/600			80
LCSLT-GD-F1568	1500*600*800/600			78
LCSLT-GD-F1588	1500*800*800/600			60
LCSLT-GD-F1868	1800*600*800/600			62
LCSLT-GD-F1888	1800*800*800/600			50
LCSLT-GD-FR1268	2-8 (°C)			1200*600*800/600
LCSLT-GD-FR1288		1200*800*800/600		80
LCSLT-GD-FR1568		1500*600*800/600	78	
LCSLT-GD-FR1588		/-15-0 (°C)	1500*800*800/600	60
LCSLT-GD-FR1868			1800*600*800/600	62
LCSLT-GD-FR1888			1800*800*800/600	50

Salad Preparation Workbench

Features

- Metal Frame
- Fold



Model	Temperature	Size (L x W x H)	Voltage (V)	Loading (40HQ)(pcs)
LCSLT-YH-R1268	2-8 (°C)	1200*600*800/600	220V	92
LCSLT-YH-R1288		1200*800*800/600		80
LCSLT-YH-R1568		1500*600*800/600		78
LCSLT-YH-R1588		1500*800*800/600		60
LCSLT-YH-R1868		1800*600*800/600		62
LCSLT-YH-R1888		1800*800*800/600		50
LCSLT-YH-F1268		-18-(-5) (°C)		1200*600*800/600
LCSLT-YH-F1288	1200*800*800/600			80
LCSLT-YH-F1568	1500*600*800/600			78
LCSLT-YH-F1588	1500*800*800/600			60
LCSLT-YH-F1868	1800*600*800/600			62
LCSLT-YH-F1888	1800*800*800/600			50
LCSLT-YH-FR1268	2-8 (°C)			1200*600*800/600
LCSLT-YH-FR1288		1200*800*800/600		80
LCSLT-YH-FR1568		1500*600*800/600	78	
LCSLT-YH-FR1588		/-15-0 (°C)	1500*800*800/600	60
LCSLT-YH-FR1868			1800*600*800/600	62
LCSLT-YH-FR1888			1800*800*800/600	50

Pizza Workbench

Features

- Metal Frame
- Fold



Model	Temperature	Size (L x W x H)	Voltage (V)	Loading (40HQ)(pcs)	
LCPST-PT-R1268	2-8 (°C)	1200*600*800/600	220V	92	
LCPST-PT-R1288		1200*800*800/600		80	
LCPST-PT-R1568		1500*600*800/600		78	
LCPST-PT-R1588		1500*800*800/600		60	
LCPST-PT-R1868		1800*600*800/600		62	
LCPST-PT-R1888		1800*800*800/600		50	
LCPST-PT-F1268	-18-(-5) (°C)	1200*600*800/600		92	
LCPST-PT-F1288		1200*800*800/600		80	
LCPST-PT-F1568		1500*600*800/600		78	
LCPST-PT-F1588		1500*800*800/600		60	
LCPST-PT-F1868		1800*600*800/600		62	
LCPST-PT-F1888		1800*800*800/600		50	
LCPST-PT-FR1268	2-8 (°C)	1200*600*800/600		92	
LCPST-PT-FR1288		1200*800*800/600		80	
LCPST-PT-FR1568		1500*600*800/600		78	
LCPST-PT-FR1588		/-15-0 (°C)		1500*800*800/600	60
LCPST-PT-FR1868				1800*600*800/600	62
LCPST-PT-FR1888				1800*800*800/600	50

Model	DLSP2818
Temperature	0-10(°C)
Voltage (V)	220V
Prower	630W
Size (L x W x H)	1800*800*1420
Capacity (L)	390L
Weight (KG)	280KG
Loading (40HQ)(pcs)	30



Model	DLSP2812
Temperature	0-10(°C)
Voltage (V)	220V
Prower	488W
Size (L x W x H)	1200*800*1420
Capacity (L)	300L
Weight (KG)	175KG
Loading (40HQ)(pcs)	44

Pizza Workbench



Model	DLSP2822
Temperature	0-10(°C)
Voltage (V)	220V
Power	800W
Size (L x W x H)	2200*800*1420
Capacity (L)	580L
Weight (KG)	280KG
Loading (40HQ)(pcs)	24



Model	DLSX1713
Temperature	0-10(°C)
Voltage (V)	220V
Power	204W
Size (L x W x H)	1365*700*1420
Capacity (L)	390L
Weight (KG)	131KG
Loading (40HQ)(pcs)	50

Model	DLSX1709
Temperature	0-10(°C)
Voltage (V)	220V
Power	204W
Size (L x W x H)	900*700*1420
Capacity (L)	250L
Weight (KG)	80KG
Loading (40HQ)(pcs)	68



Model	DLSS2812
Temperature	0-10(°C)
Voltage (V)	220V
Power	204W
Size (L x W x H)	1200*800*1420
Capacity (L)	250L
Weight (KG)	174KG
Loading (40HQ)(pcs)	52



Pizza Workbench

Pizza Workbench



Model	DLSS2815
Temperature	0-10(°C)
Voltage (V)	220V
Prower	560W
Size (L x W x H)	1510*800*1420
Capacity (L)	390L
Weight (KG)	194KG
Loading (40HQ)(pcs)	36



Model	DLSS2820
Temperature	0-10(°C)
Voltage (V)	220V
Prower	630W
Size (L x W x H)	2025*800*1420
Capacity (L)	480L
Weight (KG)	265KG
Loading (40HQ)(pcs)	26

Model	DLSS2818
Temperature	0-10(°C)
Voltage (V)	220V
Prower	630W
Size (L x W x H)	17950*700*1420
Capacity (L)	480L
Weight (KG)	225KG
Loading (40HQ)(pcs)	34



Model	DLSS2820T
Temperature	0-10(°C)
Voltage (V)	220V
Prower	630W
Size (L x W x H)	2025*800*1420
Capacity (L)	390L
Weight (KG)	278KG
Loading (40HQ)(pcs)	26



Pizza Workbench

Pizza Workbench



Model	DLSS2815
Temperature	0-10(°C)
Voltage (V)	220V
Prower	560W
Size (L x W x H)	1510*800*1420
Capacity (L)	390L
Weight (KG)	194KG
Loading (40HQ)(pcs)	36

Model	DLSS2818
Temperature	0-10(°C)
Voltage (V)	220V
Prower	630W
Size (L x W x H)	17950*700*1420
Capacity (L)	480L
Weight (KG)	225KG
Loading (40HQ)(pcs)	34



Ice Machine



Model	SLXB-200	SLXB-250	SLXB-300	SLXB-380	SLXB-500
Voltage (V)	220V	220V	220V	220V	220V
Prower	1350W	1450W	1800W	2500W	3000W
Daily Output(KG)	200KG	250KG	300KG	380KG	500KG
Size (L x W x H)	565*820*1715	565*820*1715	565*820*1815	760*850*1735	760*850*1815
Cooling type	Water Cooling	Water Cooling	Water Cooling	Water Cooling	Water Cooling
Storage Capacity(KG)	140KG	140KG	140KG	200KG	200KG
Inlet Water Pressure(Kpa)	130-550	130-550	130-550	130-550	130-550
Weight (KG)	100KG	115KG	120KG	155KG	170KG
Loading (40HQ)(pcs)	72	72	70	58	50

Ice Machine



Model	SLKK-50	SLKK-68	SLKK-80	SLKK-90	SLKK-130
Voltage (V)	220V	220V	220V	220V	220V
Power	290W	420W	480W	450W	750W
Daily Output(KG)	50KG	68KG	80KG	90KG	130KG
Size (L x W x H)	404*499*789	500*585*903	605*585*910	605*585*910	760*760*1020
Cooling type	Water Cooling	Water Cooling	Water Cooling	Water Cooling	Water Cooling
Storage Capacity(KG)	11KG	12KG	30KG	30KG	40KG
Inlet Water Pressure(Kpa)	130-550	130-550	130-550	130-550	130-550
Weight (KG)	32KG	51KG	46KG	46KG	60KG
Loading (40HQ)(pcs)	360	240	190	190	108

Commercial Steamer

Features

- Electric Heating
- Rapid Heating



Model	ZFCDR-S4	ZFCDR-S6	ZFCDR-4	ZFCDR-6
Voltage	220V	220V	220V	220V
Power	2.8KW	2.8KW	6KW	6KW
Layers	4	6	4	6
Size(L x W x H)	390*550*690	390*550*860	680*580*780	680*580*950
Heating method	Electric heating	Electric heating	Electric heating	Electric heating
Intelligent temperature control	/	/	/	/
Loading (40HQ)(pcs)	440	350	226	180



Model	ZFCDR-8	ZFCDR-10	ZFCDR-12	ZFCDR-24
Voltage	220V	220V	220V	220V
Power	6/9KW	8/12KW	8/12KW	18/24KW
Layers	8	10	12	24
Size (L x W x H)	680*580*1120	680*580*1290	680*580*1380	138*580*1460
Heating method	Electric heating	Electric heating	Electric heating	Electric heating
Intelligent temperature control	/	/	/	/
Loading (40HQ)(pcs)	150	130	120	45

Features

- Temperature Control
- Time Control



Model	ZFCZN-S4	ZFCZN-S6	ZFCZN-4	ZFCZN-6
Voltage	220V	220V	220V	220V
Power	2.8KW	2.8KW	6KW	6KW
Layers	4	6	4	6
Size (L x W x H)	390*550*690	390*550*860	680*580*780	680*580*950
Heating method	Electric heating	Electric heating	Electric heating	Electric heating
Intelligent temperature control	√	√	√	√
Loading (40HQ)(pcs)	440	350	226	180



Model	ZFCZN-8	ZFCZN-10	ZFCZN-12	ZFCZN-24
Voltage	220V	220V	220V	220V
Power	6/9KW	8/12KW	8/12KW	18/24KW
Layers	8	10	12	24
Size (L x W x H)	680*580*1120	680*580*1290	680*580*1380	138*580*1460
Heating method	Electric heating	Electric heating	Electric heating	Electric heating
Intelligent temperature control	√	√	√	√
Loading (40HQ)(pcs)	150	130	120	45

Features

- Gas Heating
- Temperature Control



Model	ZFCRQ-4	ZFCRQ-6	ZFCRQ-8
Air pressure (pa)	2000Pa	2000Pa	2000Pa
Layers	4	6	8
Size(L x W x H)	680*650*920	680*650*1090	680*650*1260
Heating method	Natural gas/liquefied gas	Natural gas/liquefied gas	Natural gas/liquefied gas
Loading (40HQ)(pcs)	155	128	110



Model	ZFCRQ-10	ZFCRQ-12	ZFCRQ-24
Air pressure (pa)	2000Pa	2000Pa	2000Pa
Layers	10	12	24
Size(L x W x H)	680*650*1430	680*650*160	1380*650*1600
Heating method	Natural gas/liquefied gas	Natural gas/liquefied gas	Natural gas/liquefied gas
Loading (40HQ)(pcs)	100	90	45

Commercial Steamer

Features

- Barometric Pressure Display
- Project Money
- Large Size



Model	ZFCYL-4	ZFCYL-6	ZFCYL-8	ZFCYL-10	ZFCYL-12	ZFCYL-24
Air pressure (pa)	2000Pa	2000Pa	2000Pa	2000Pa	2000Pa	2000Pa
Layers	4	6	8	10	12	24
Size (L x W x H)	680*550*960	680*550*1130	680*550*1300	680*550*1470	680*550*1640	1390*550*1640
Heating method	Natural gas/liquefied gas	Natural gas/liquefied gas	Natural gas/liquefied gas	Natural gas/liquefied gas	Natural gas/liquefied gas	Natural gas/liquefied gas
Loading (40HQ)(pcs)	180	150	130	120	104	52

Model	SLWL-6F
Layers	6
Size (L x W x H)	600*790*1100
Temperature Range	Ambient Temperature-85 (°C)
Humidity range	Ambient Humidity-85%RH
Prower	2600W
weight (KG)	25KG
Loading (40HQ)(pcs)	112



Model	SLWL-13F
Layers	13
Size (L x W x H)	600*790*1865
Temperature Range	Ambient Temperature-85 (°C)
Humidity range	Ambient Humidity-85%RH
Prower	2600W
weight (KG)	35KG
Loading (40HQ)(pcs)	70

Fermentation Box

Fermentation Box

Model	SLWL-16F
Layers	16
Size (L x W x H)	600*790*2135
Temperature Range	Ambient Temperature-85 (°C)
Humidity range	Ambient Humidity-85%RH
Prower	2600W
weight (KG)	55KG
Loading (40HQ)(pcs)	60



Model	SLWL-32F
Layers	32
Size (L x W x H)	1110*790*2035
Temperature Range	Ambient Temperature-85 (°C)
Humidity range	Ambient Humidity-85%RH
Prower	2800W
weight (KG)	80KG
Loading (40HQ)(pcs)	40



Model	SLWL-26F
Layers	26
Size (L x W x H)	1110*790*1765
Temperature Range	Ambient Temperature-85 (°C)
Humidity range	Ambient Humidity-85%RH
Prower	2800W
weight (KG)	80KG
Loading (40HQ)(pcs)	48

Features

- Precise temperature control
- Automatic water supply
- Hot air circulation
- Uniform humidity

Fermentation Box

Commercial Oven

Features

- Dashboard
- Electric Oven



Model	Specification	Size (L x W x H)	Voltage(V)	Power(KW)	Loading (40HQ)(pcs)
SL-11D	(1-Deck 1-Tray)	920*600*460	220V	3.2KW	230
SL-12D	(1-Deck 2-Tray)	1240*800*600	220V	6.6KW	110
SL-22D	(2-Deck 2-Tray)	920*600*920	220V	6.6KW	114
SL-24D	(2-Deck 4-Tray)	920*600*920	380/3N	13.2KW	114
SL-33D	(3-Deck 3-Tray)	920*600*1260	380/3N	9.6KW	88
SL-36D	(3-Deck 6-Tray)	1240*800*1550	380/3N	18KW	50
SL-39D	(3-Deck 9-Tray)	1720*800*1640	380/3N	24KW	28
SL-416D	(4-Deck 16-Tray)	1650*950*1800	380/3N	42KW	24

Commercial Oven

Features

- Dashboard
- Gas Oven



Model	Specification	Size (L x W x H)	Voltage(V)	Power(KW)	Loading (40HQ)(pcs)
SL-11Q	(1-Deck 1-Tray)	1060*750*620	220V	0.3	122
SL-12Q	(1-Deck 2-Tray)	1320*860*615	220V	0.5	86
SL-22Q	(2-Deck 2-Tray)	920*600*920	220V	0.5	114
SL-24Q	(2-Deck 4-Tray)	920*600*920	220V	1	114
SL-33Q	(3-Deck 3-Tray)	650*470*1260	220V	1	164
SL-36Q	(3-Deck 6-Tray)	890*640*1500	220V	1	120
SL-39Q	(3-Deck 9-Tray)	1320*640*1630	220V	1.5	48
SL-312Q	(3-Deck 12-Tray)	1760*1100*1720	220V	1.5	20
SL-416Q	(4-Deck 16-Tray)	1760*1100*2100	220V	1.5	16

Commercial Oven

Features

- Cleaning Spraygun
- Rack



Model	ST-6P	ST-10P	ST-20P
Size (L x W x H)	900*800*850mm	900*800*1100mm	900*800*1850mm
The palletsize	330*530*65mm	330*530*65mm	330*530*65mm
Rated power	6-11kW	19kW	37kW
Rated voltage	220v-380v	380v	380v
Steamoven base	900*800*700mm	900*800*700mm	0
Loading (40HQ)(pcs)	100	74	48

Multifunctional oven for all cooking scenarios. Rugged and durable, intelligent digital display,

intelligent operation

Milk Warming Cabinet



Model	SL-BW-WS120	SL-BW-WS150	SL-BW-WS260	SL-BW-WS800	SL-BW-WS1200
Temperature	40-60(°C)				
Voltage (V)	220V	220V	220V	220V	220V
Size (L x W x H)	520*475*1230	600*600*1480	600*510*1750	1200*600*1910	1800*600*1910
Capacity (L)	120L	150L	260L	800L	1200L
Compressor location	TOP	TOP	TOP	TOP	TOP
Loading (40HQ)(pcs)	200	102	98	65	36



Model	SL-BW-XJ380	SL-BW-XJ680	SL-BW-XJ110
Temperature	40-60(°C)		
Voltage (V)	220V	220V	220V
Size (L x W x H)	600*510*1960	1200*580*1960	1800*580*1960
Capacity (L)	380L	680L	1100L
Compressor location	Bottom	Bottom	Bottom
Loading (40HQ)(pcs)	90	48	32

Milk Warming Cabinet



Model	SL-BW-KT52L	SL-BW-KT68L	SL-BW-KT80L	SL-BW-KT98L	SL-BW-KT108L
Temperature	25-60(°C)				
Voltage (V)	220V	220V	220V	220V	220V
Size (L x W x H)	430*380*620	430*380*720	430*380*840	430*380*950	430*380*1050
Capacity (L)	52L	68L	88L	98L	108L
Loading (40HQ)(pcs)	90	48	32	32	32

Various Colors



Heated Sales Counter



Model	HHBWS-120	HHBWS-150	HHBWS-180	HHBWS-210
Power (W)	280W	280W	280W	280W
Voltage (V)	220V	220V	220V	220V
Size (L x W x H)	1200*700* (850+500)	1500*700* (850+500)	1800*700* (850+500)	2100*700*(850+50)
Material	201-304 Grade stainless steel			
Temperature	0-80(°C)	0-80(°C)	0-80(°C)	0-80(°C)
Weight (KG)	80KG	85KG	90KG	95KG
Loading (40HQ)(pcs)	105	85	70	60



Model	HLBSS-120	HLBSS-150	HLBSS-180	HHLBSS-210
Power (W)	280W	280W	280W	280W
Voltage (V)	220V	220V	220V	220V
Size (L x W x H)	1200*700* (850+500)	1500*700* (850+500)	1800*700* (850+500)	2100*700* (850+500)
Temperature	0-80(°C)	0-80(°C)	0-80(°C)	0-80(°C)
Material	201-304 Grade stainless steel			
Weight (KG)	80KG	85KG	90KG	95KG
Loading (40HQ)(pcs)	105	85	70	60

Heated Sales Counter



Model	JBTD-120	JBTD-150	JBTD-180	JBTD-210
Power (W)	280W	280W	280W	280W
Voltage (V)	220V	220V	220V	220V
Size (L x W x H)	1200*700* (850+500)	1500*700* (850+500)	1800*700* (850+500)	2100*700* (850+500)
Temperature	0-80(°C)	0-80(°C)	0-80(°C)	0-80(°C)
Material	201-304 Grade stainless steel			
Weight (KG)	80KG	85KG	90KG	95KG
Loading (40HQ)(pcs)	105	85	70	60



Model	JBTYS120	JBTYS-150	JBTYS-180	JBTYS-210
Power (W)	280W	280W	280W	280W
Voltage (V)	220V	220V	220V	220V
Size (L x W x H)	1200*700* (850+500)	1500*700* (850+500)	1800*700* (850+500)	2100*700* (850+500)
Temperature	0-80(°C)	0-80(°C)	0-80(°C)	0-80(°C)
Material	201-304 Grade stainless steel			
Weight (KG)	80KG	85KG	90KG	95KG
Loading (40HQ)(pcs)	105	85	70	60

Heated Sales Counter



Model	JBTSL-120	JBTSL-150	JBTSL-180	JBTSL-210
Power (W)	280W	280W	280W	280W
Voltage (V)	220V	220V	220V	220V
Size (L x W x H)	1200*700* (850+500)	1500*700* (850+500)	1800*700* (850+500)	2100*700* (850+500)
Material	201-304 Grade stainless steel			
Temperature	0-80(°C)	0-80(°C)	0-80(°C)	0-80(°C)
Weight (KG)	80KG	85KG	90KG	95KG
Loading (40HQ)(pcs)	105	85	70	60

Model	D-DT3A
Power (KW)	1.8
Voltage (V)	220V-240
Size (L x W x H)	960*360*350
Temperature	0-80(°C)
Container	3
Loading (40HQ)(pcs)	630
Material	201-304 Grade stainless steel



Model	D-DT4A
Power (KW)	1.8
Voltage (V)	220V-240
Size (L x W x H)	1230*360*350
Temperature	0-80(°C)
Container	4
Loading (40HQ)(pcs)	490
Material	201-304 Grade stainless steel

Heated Sales Counter

Model	D-DT5A
Power (KW)	1.8
Voltage (V)	220V-240
Size (L x W x H)	1500*360*350
Temperature	0-80(°C)
Container	5
Loading (40HQ)(pcs)	400
Material	201-304 Grade stainless steel



Model	D-DT6A
Power (KW)	3
Voltage (V)	220V-240
Size (L x W x H)	1770*360*350
Temperature	0-80(°C)
Container	6
Loading (40HQ)(pcs)	320
Material	201-304 Grade stainless steel



Model	D-DT3
Power (KW)	1.8
Voltage (V)	220V-240
Size (L x W x H)	340*560*280
Temperature	0-80(°C)
Container	3
Loading (40HQ)(pcs)	1400
Material	201-304 Grade stainless steel



Model	D-DT6
Power (KW)	1.8
Voltage (V)	220V-240
Size (L x W x H)	1020*560*280
Temperature	0-80(°C)
Container	6
Loading (40HQ)(pcs)	400
Material	201-304 Grade stainless steel



Food Warmer Cart

Model	D-BWC-FDB-2
Power (KW)	1.8
Voltage (V)	220V-240
Size (L x W x H)	1280*715*1340
Temperature	30-80(°C)
Weight (KG)	170
Loading (40HQ)(pcs)	54
Material	304 Grade stainless steel



Model	E-BWC-15-11
Power (KW)	1
Voltage (V)	220V-240
Size (L x W x H)	555*740*1500
Temperature	30-80(°C)
Weight (KG)	70
Loading (40HQ)(pcs)	110
Material	304 Grade stainless steel



Model	E-BWS-7-11
Power (KW)	1
Voltage (V)	220V-240
Size (L x W x H)	555*740*960
Temperature	30-80(°C)
Weight (KG)	90
Loading (40HQ)(pcs)	160
Material	201/304 Grade stainless steel



Food Warmer Cart

Model	E-DBW-11-21-4B
Power (KW)	2.52
Voltage (V)	220V-240
Size (L x W x H)	730*800*1860
Temperature	30-80(°C)
Weight (KG)	70
Loading (40HQ)(pcs)	70
Material	304 Grade stainless steel



Model	E-DBW-22B-21
Power (KW)	2.52
Voltage (V)	220V-240
Size (L x W x H)	1540*940*1860
Temperature	35-80(°C)
Weight (KG)	140
Loading (40HQ)(pcs)	32
Material	304 Grade stainless steel

Model	E-BWC-4CD
Power (KW)	1.3
Voltage (V)	220V-240
Size (L x W x H)	1040*730*930
Temperature	30-80(°C)
Weight (KG)	125
Loading (40HQ)(pcs)	100
Material	201/304 Grade stainless steel



Disinfection Cabinet



Model	Name	Size (L x W x H)	Power(W)	Material	Function	Loading (40HQ)(pcs)
RH280	Single-door disinfection cabinet	560*500*1200	600w	201 Grade stainless steel	Infrared, ozone disinfection, ultraviolet, hot air circulation	220
RH380-1	Single-door disinfection cabinet	560*500*1650	600w			150
RH380-2	Upper and lower door disinfection cabinet	560*500*1650	900w			150
RH800	Double-door disinfection cabinet	1000*500*1600	1200w			95
RH900	Double-door disinfection cabinet	1120*500*1650	1200w			74
RH980	Double-door disinfection cabinet	1200*500*1700	1200w		70	

Disinfection Cabinet



Model	DMRF-1
Size (L x W x H)	650*650*1920
Material	201Grade stainless steel
Thickness	0.6mm
Power(W)	2200
Temperature	20-125 (°C)
Loading (40HQ)(pcs)	90

Model	DMRF-2
Size (L x W x H)	1300*650*1920
Material	201Grade stainless steel
Thickness	0.6mm
Power(W)	44000
Temperature	20-125 (°C)
Loading (40HQ)(pcs)	46



Model	DMXH-1
Size (L x W x H)	650*650*1920
Material	201Grade stainless steel
Thickness	0.6mm
Power(W)	2200
Temperature	20-125 (°C)
Loading (40HQ)(pcs)	90

Model	DMXH-2
Size (L x W x H)	1300*650*1920
Material	201Grade stainless steel
Thickness	0.6mm
Power(W)	44000
Temperature	20-125 (°C)
Loading (40HQ)(pcs)	46



Model	CP-CB12-H
Size (L x W x H)	304*728*394
Package Dimension (mm)	400*850*440
BTU/h	40000
Temperature control button	2
Loading (40HQ)(pcs)	335



Model	CP-CB24-H
Size (L x W x H)	609*728*394
Package Dimension (mm)	700*850*440
BTU/h	80000
Temperature control button	4
Loading (40HQ)(pcs)	215

Model	CP-CB36-H
Size (L x W x H)	914*728*394
Package Dimension (mm)	1000*850*440
BTU/h	120000
Temperature control button	6
Loading (40HQ)(pcs)	130



Model	CP-CB48-H
Size (L x W x H)	1220*728*394
Package Dimension (mm)	1300*850*490
BTU/h	160000
Temperature control button	8
Loading (40HQ)(pcs)	110

Model	CP-CB12-M
Size (L x W x H)	304*728*394
Package Dimension (mm)	400*850*440
BTU/h	35000
Temperature control button	1
Loading (40HQ)(pcs)	335



Model	CP-G24-T
Size (L x W x H)	609*728*394
Package Dimension (mm)	700*850*490
BTU/h	56000
Temperature control button	2
Loading (40HQ)(pcs)	215



Model	CP-CB24-M
Size (L x W x H)	609*728*394
Package Dimension (mm)	700*850*440
BTU/h	70000
Temperature control button	2
Loading (40HQ)(pcs)	215



Model	CP-G36-T
Size (L x W x H)	914*728*394
Package Dimension (mm)	1000*850*490
BTU/h	84000
Temperature control button	3
Loading (40HQ)(pcs)	130

Model	CP-CB36-M
Size (L x W x H)	914*728*394
Package Dimension (mm)	1000*850*440
BTU/h	105000
Temperature control button	3
Loading (40HQ)(pcs)	130



Model	CP-G12-M
Size (L x W x H)	304*728*394
Package Dimension (mm)	400*850*490
BTU/h	30000
Temperature control button	1
Loading (40HQ)(pcs)	335



Model	CP-CB48-M
Size (L x W x H)	1220*728*394
Package Dimension (mm)	1300*850*490
BTU/h	140000
Temperature control button	4
Loading (40HQ)(pcs)	110



Model	CP-G24-M
Size (L x W x H)	609*728*394
Package Dimension (mm)	700*850*490
BTU/h	60000
Temperature control button	2
Loading (40HQ)(pcs)	215

Model	CP-G36-M
Size (L x W x H)	914*728*394
Package Dimension (mm)	1000*850*490
BTU/h	90000
Temperature control button	3
Loading (40HQ)(pcs)	130



Model	CP-24GE-T
Size (L x W x H)	609*728*394
Package Dimension (mm)	700*850*490
Power (KW)	6.0/8.0
Voltage (V)	208/240
Temperature control button	2
Loading (40HQ)(pcs)	215



Model	CP-G48-M
Size (L x W x H)	1220*728*394
Package Dimension (mm)	1300*850*490
BTU/h	120000
Temperature control button	4
Loading (40HQ)(pcs)	110



Model	CP-36GE-T
Size (L x W x H)	914*728*394
Package Dimension (mm)	1000*850*490
Power (KW)	9.0/12.0
Voltage (V)	208/240
Temperature control button	3
Loading (40HQ)(pcs)	130

Model	CP-G60-M
Size (L x W x H)	1530*728*394
Package Dimension (mm)	1600*850*490
BTU/h	150000
Temperature control button	5
Loading (40HQ)(pcs)	56



Model	CP-48GE-T
Size (L x W x H)	1220*728*394
Package Dimension (mm)	1300*850*490
Power (KW)	12.0/16.0
Voltage (V)	208/240
Temperature control button	4
Loading (40HQ)(pcs)	110



Commercial Gas Stove

Model	CP-R24
Size (L x W x H)	610*800*1520
Package Dimension (mm)	700*930*1190
K/BTU	153/136
top burner	4
Loading (40HQ)(pcs)	72



Model	CP-R36
Size (L x W x H)	910*800*1520
Package Dimension (mm)	1000*930*1110
K/BTU	213 / 190
top burner	6
Loading (40HQ)(pcs)	48



Model	CP-R48
Size (L x W x H)	1220*800*1520
Package Dimension (mm)	1300*930*1110
K/BTU	306 / 272
top burner	8
Loading (40HQ)(pcs)	42



Model	CP-R60
Size (L x W x H)	1530*800*1520
Package Dimension (mm)	1600*930*1110
K/BTU	366 / 326
top burner	10
Loading (40HQ)(pcs)	28



Model	CP-F3
Size (L x W x H)	394*794*1150
Package Dimension (mm)	420*820*850
Gas	NG/LP
Oil volume	35-40LBS
BTU/h	90000
Burner	3
Loading (40HQ)(pcs)	210



Fryer

Model	CP-F4
Size (L x W x H)	394*794*1150
Package Dimension (mm)	420*820*850
Gas	NG/LP
Oil volume	40-50LBS
BTU/h	120000
Burner	4
Loading (40HQ)(pcs)	210



Model	CP-F5
Size (L x W x H)	534*873*1150
Package Dimension (mm)	570*920*850
Gas	NG/LP
Oil volume	75-80LBS
BTU/h	150000
Burner	5
Loading (40HQ)(pcs)	42



Dough Mixer

Features

- Automatic lifting
- Copper core motor



Model	JBJ-SJB10	JBJ-SJB15	JBJ-SJB20	JBJ-SJB30
Size (L x W x H)	383*467*618	383*479*688	432*537*780	432*555*855
Weight (KG)	63KG	65KG	76KG	83KG
Power (W)	550W	550W	1100W	1100W
Speed/min	113/184/341	113/184/341	108/161/382	108/161/382
Maximum Mixing Volume	1KG	1.5KG	3KG	4KG
Loading (40HQ)(pcs)	520	520	316	280



Model	JBJ-QJ10	JBJ-QJ15	JBJ-QJ20	JBJ-QJ30
Size (L x W x H)	450*350*640	450*350*660	432*537*780	540*460*900
Weight (KG)	50KG	53KG	76KG	79KG
Power (W)	550W	550W	1100W	1500W
Speed/min	110/360	110/360	105/180/408	105/180/408
Maximum Mixing Volume	1.5-2.5KG	1.5-3KG	1.5-4KG	1.5-6KG
Loading (40HQ)(pcs)	540	530	380	280

Dough Mixer

Features

- Two speed double action
- Protective Cover



Model	H20F	H30F	H50F	H60F
Size (L x W x H)	630*380*750	710*450*850	740*520*880	880*520*1040
Weight (KG)	80KG	105KG	120KG	120KG
Mixing head speed	230/120	230/120	230/120	108/161/382
Barrel speed	18/10	18/10	18/10	18/10
Maximum Mixing Volume	8KG	12.5KG	18KG	25KG
Loading (40HQ)(pcs)	338	224	204	138

Features

- High Speed
- Alloy Body



Model	LFP30	LFP40	LFP50	LFP60
Size (L x W x H)	600*530*890	630*560*950	850*580*1160	870*630*1220
Power (KW)	1.8	2.2	2.6	3.5
Speed	88/168/292	88/168/292	82/132/288	82/132/288
Maximum Mixing Volume	8KG	12KG	15KG	18KG
Loading (40HQ)(pcs)	234	194	118	100

Model	KST-30BZ
Size (L x W x H)	600*530*890
Blade diameter (mm)	300
Cutting thickness (mm)	0-6
cutting width (mm)	160
cutting speed	42
weight (KG)	46
Loading (40HQ)(pcs)	230



Model	KST-30JT
Size (L x W x H)	520*450*660
Blade diameter (mm)	300
Cutting thickness (mm)	0-6
cutting width (mm)	160
cutting speed	42
weight (KG)	46
Function	Emergency stop
Loading (40HQ)(pcs)	230



Model	KST-30MJY
Size (L x W x H)	520*450*660
Blade diameter (mm)	300
Cutting thickness (mm)	0-6
cutting width (mm)	160
cutting speed	42
weight (KG)	46
Loading (40HQ)(pcs)	340



Model	KST-31SJ
Size (L x W x H)	540*450*740
Blade diameter (mm)	300
Cutting thickness (mm)	0-12
cutting width (mm)	200
cutting speed	42
weight (KG)	55
Function	Emergency stop
Loading (40HQ)(pcs)	216

Model	KST-30SJ
Size (L x W x H)	520*450*660
Blade diameter (mm)	300
Cutting thickness (mm)	0-6
cutting width (mm)	160
cutting speed	42
weight (KG)	46
Loading (40HQ)(pcs)	340



Model	KST-32JT
Size (L x W x H)	780*560*740
Blade diameter (mm)	320
Cutting thickness (mm)	0-12
cutting width (mm)	200
cutting speed	42
weight (KG)	86
Function	Emergency stop
Loading (40HQ)(pcs)	200



Strength

Products

Commercial Kitchen Cleaning Equipment

- ODM&OEM
- Price advantage
- Fast delivery
- Manufacturer

Model	CSB-QJ60
External (L x W x H)	600*550*800(+140Faucet)
Inside (L x W x H)	500*400*290
Capacity (L)	58
Power(KW)	4.5
Loading (40HQ)(pcs)	263



Model	CSB-QJ80
External (L x W x H)	800*750*800(+140Faucet)
Inside (L x W x H)	700*600*290
Capacity (L)	121.8
Power(KW)	4.5
Loading (40HQ)(pcs)	148

Model	CSB-QJ100
External (L x W x H)	1000*750*800(+140Faucet)
Inside (L x W x H)	800*600*290
Capacity (L)	157
Power(KW)	6
Loading (40HQ)(pcs)	118



Model	CSB-QJ120
External (L x W x H)	1200*750*800(+140Faucet)
Inside (L x W x H)	1100*600*290
Capacity (L)	192
Power(KW)	6
Loading (40HQ)(pcs)	98



Ultrasonic Dishwasher

Model	CSB-Q150
External (L x W x H)	1500*750*800(+140Faucet)
Inside (L x W x H)	1400*600*290
Capacity (L)	245
Power(KW)	6
Loading (40HQ)(pcs)	80



Model	CSB-2QJ200
External (L x W x H)	2000*750*800(+140Faucet)
Inside (L x W x H)	2000*600*290
Capacity (L)	330
Power(KW)	9
Loading (40HQ)(pcs)	60



Model	CSB-QJ180
External (L x W x H)	1800*750*800(+140Faucet)
Inside (L x W x H)	1700*600*290
Capacity (L)	300
Power(KW)	9
Loading (40HQ)(pcs)	68



Model	CSB-GC80
External (L x W x H)	800*700*950
Inside (L x W x H)	660*470*300
Capacity (L)	93.
Power(KW)	3
Loading (40HQ)(pcs)	155

Model	CSB-QJ200
External (L x W x H)	2000*750*800(+140Faucet)
Inside (L x W x H)	1900*600*290
Capacity (L)	330
Power(KW)	9
Loading (40HQ)(pcs)	60



Model	CSB-GC100
External (L x W x H)	1000*700*950
Inside (L x W x H)	860*470*300
Capacity (L)	120
Power(KW)	4.5
Loading (40HQ)(pcs)	108



Model	CSB-2QJ180
External (L x W x H)	1800*750*800(+140Faucet)
Inside (L x W x H)	1600*600*290
Capacity (L)	300
Power(KW)	9
Loading (40HQ)(pcs)	68



Model	CSB-GC120
External (L x W x H)	1200*700*800
Inside (L x W x H)	1060*470*300
Capacity (L)	150
Power(KW)	5
Loading (40HQ)(pcs)	90

Ultrasonic Dishwasher

Model	CSB-GC150
External (L x W x H)	1500*700*950
Inside (L x W x H)	1360*470*300
Capacity (L)	192
Power(KW)	5.2
Loading (40HQ)(pcs)	72



Ultrasonic Dishwasher

Model	CSB-2GC200
External (L x W x H)	2000*700*950
Inside (L x W x H)	1760*470*300
Capacity (L)	250
Power(KW)	7.5
Loading (40HQ)(pcs)	54



Model	CSB-GC180
External (L x W x H)	1800*700*950
Inside (L x W x H)	1660*470*300
Capacity (L)	230
Power(KW)	5.8
Loading (40HQ)(pcs)	60

Model	CSB-2GC180
External (L x W x H)	1800*700*950
Inside (L x W x H)	1560*470*300
Capacity (L)	220
Power(KW)	7
Loading (40HQ)(pcs)	60



Model	CSB-GC200
External (L x W x H)	2000*700*950
Inside (L x W x H)	1860*470*300
Capacity (L)	262
Power(KW)	6
Loading (40HQ)(pcs)	54

Features

- Full size customization
- High frequency fast cleaning
- 304 stainless steel heating
- Intelligent protection against dry burning and water and power outages.
- Timing temperature control

Commercial Dishwashers

Model	WS170
Product Size(mm)	1700*890*1450
Total power consumption(KW)	34.6
Module composition(L/H)	Wash + spray
Water Consumption	300
Drying power	/
Cleaning width (mm)	560
Cleaning ability(dish)	1200
Water pump power(KW)	2.25
Cleaning/Rinse power(KW)	6/27



Model	WS320
Product Size(mm)	3200*890*140
Total power consumption(KW)	42.35
Module composition(L/H)	Wash *2+ spray*2
Water Consumption	300
Drying power	/
Cleaning width (mm)	560
Cleaning ability(dish)	3600
Water pump power(KW)	3.75
Cleaning/Rinse power(KW)	12/27



Model	WS270
Product Size(mm)	2700*890*1450
Total power consumption(KW)	42.35
Module composition(L/H)	Wash *2+ spray
Water Consumption	300
Drying power	/
Cleaning width (mm)	560
Cleaning ability(dish)	2500
Water pump power(KW)	3.75
Cleaning/Rinse power(KW)	12/27



Model	WS350
Product Size(mm)	3500*890*1860
Total power consumption(KW)	56.1
Module composition(L/H)	Wash + spray+drying
Water Consumption	300
Drying power	21.5
Cleaning width (mm)	560
Cleaning ability(dish)	2500
Water pump power(KW)	2.25
Cleaning/Rinse power(KW)	6/27

Commercial Dishwashers

Model	WS450
Product Size(mm)	4500*890*1950
Total power consumption(KW)	63.9
Module composition(L/H)	Wash*2+ spray*2+drying*1
Water Consumption	300
Drying power	21.5
Cleaning width (mm)	560
Cleaning ability(dish)	4000
Water pump power(KW)	3.75
Cleaning/Rinse power(KW)	12/27



Model	WS590
Product Size(mm)	5900*890*1950
Total power consumption(KW)	81.15
Module composition(L/H)	Wash*2+ spray*2+drying*2
Water Consumption	300
Drying power	21.5*2
Cleaning width (mm)	560
Cleaning ability(dish)	6000
Water pump power(KW)	3.75
Cleaning/Rinse power(KW)	12/27

Commercial Dishwashers

Model	WSZ295
Product Size(mm)	2950*900*1600
Total power consumption(KW)	45.05
Module composition(L/H)	Wash *2+ spray
Water Consumption	300
Drying power	/
Cleaning width (mm)	620
Cleaning ability(dish)	6000
Water pump power(KW)	31.5
Cleaning/Rinse power(KW)	9/33



Model	WSZ375
Product Size(mm)	3750*900*1600
Total power consumption(KW)	56.45
Module composition(L/H)	Wash *2+ spray*2
Water Consumption	300
Drying power	/
Cleaning width (mm)	620
Cleaning ability(dish)	9000
Water pump power(KW)	5.55
Cleaning/Rinse power(KW)	9*2/33

Commercial Dishwashers

Model	WSZ445
Product Size(mm)	4450*900*2050
Total power consumption(KW)	54.8
Module composition(L/H)	Wash+ spray*2+drying
Water Consumption	300
Drying power	9.75
Cleaning width (mm)	620
Cleaning ability(dish)	6000
Water pump power(KW)	3.15
Cleaning/Rinse power(KW)	9/33



Commercial Dishwashers

Model	WSZ545
Product Size(mm)	5450*900*2050
Total power consumption(KW)	66.3
Module composition(L/H)	Wash*2+ spray*2+drying*2
Water Consumption	300
Drying power	9.75
Cleaning width (mm)	620
Cleaning ability(dish)	9000
Water pump power(KW)	5.55
Cleaning/Rinse power(KW)	9/33

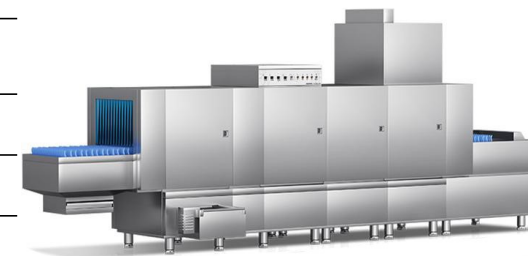

Model	WSZ515
Product Size(mm)	5150*900*2050
Total power consumption(KW)	65.5
Module composition(L/H)	Wash*2+ spray*2+drying*1
Water Consumption	300
Drying power	9.75
Cleaning width (mm)	620
Cleaning ability(dish)	9000
Water pump power(KW)	5.55
Cleaning/Rinse power(KW)	9*2/33



Model	WSZ585
Product Size(mm)	5850*900*2050
Total power consumption(KW)	75.95
Module composition(L/H)	Wash*2+ spray*2+drying*2
Water Consumption	300
Drying power	9.75*2
Cleaning width (mm)	620
Cleaning ability(dish)	9000
Water pump power(KW)	5.55
Cleaning/Rinse power(KW)	9*2/27



Commercial Dishwashers

Model	BLWS170
Product Size(mm)	1700*890*1450
Visible	√
Visible Voltage(V)	220V
Rinsing temperature(°C)	85-90
Water Consumption	2.5-3.5(L/once)
Cleaning mode	60S/90S/120S
Cleaning width (mm)	50-60once/H
Cleansing power	9.73
Product material	Food grade 304



Model	FGWS170
Product Size(mm)	1700*890*1450
Visible	/
Visible Voltage(V)	220V
Rinsing temperature(°C)	85-90
Water Consumption	2.5-3.5(L/once)
Cleaning mode	60S/90S/120S
Cleaning width (mm)	50-60once/H
Cleansing power	9.73
Product material	Food grade 304

Foot/Knee Operated Hand Wash Sink



Model	K-WS1	K-WS2	K-WS3	K-WS4	K-WS5
Size (L x W x H)	330*400*575	330*400* (270+60)	330*400* (270+150)	400*400* (300+60)	400*400* (270+250)
Internal size (LxWxH)	380*450*630	380*450*380	380*450*470	450*450*410	450*450*570
Material	201-304 Grade stainless steel				
Thickness	1.0mm/1.2mm				
Name	Knee operated wash hand sink				
Loading (40HQ)(pcs)	700	1100	880	750	620



Model	F-WS1
Size (L x W x H)	500*400* (800+150)
Internal size (LxWxH)	540*540*1000
Material	201-304 Grade stainless steel
Thickness	1.0mm/1.2mm
Name	Foot operated wash hand sink
Loading (40HQ)(pcs)	260

Model	F-WS2
Size (L x W x H)	500*400* (800+50)
Internal size (LxWxH)	540*540*900
Material	201-304 Grade stainless steel
Thickness	1.0mm/1.2mm
Name	Foot operated wash hand sink
Loading (40HQ)(pcs)	280



Foot/Knee Operated Hand Wash Sink

Wash Sink

Features

The appearance, size and packaging can be customized freely according to your needs.



Model	S-S11	S-S12	S-S13	S-S14
Size (L x W x H)	500*500*800/850	600*600*800/850	700*700*800/850	1000*700*800/850
Material	201-304 Grade stainless steel			
Thickness	0.8/1.0mm/1.2mm			
Loading (40HQ)(pcs)	280	230	170	120



Model	S-S21	S-S22	S-S23	S-S24	S-S25	S-S26
Size (L x W x H)	1000*500*800/ 850	1000*600*800/ 850	1200*600*800/ 850	1200*700*800/ 850	1400*700*800/ 850	1500*700*800/ 850
Material	201-304 Grade stainless steel					
Thickness	0.8/1.0mm/1.2mm					
Loading (40HQ)(pcs)	170	140	110	100	86	75

Wash Sink



Model	S-S31	S-S32	S-S33	S-S34
Size (L x W x H)	1450*500*800/850	1450*600*800/850	1800*600*800/850	1800*700*800/850
Material	201-304 Grade stainless steel			
Thickness	0.8/1.0mm/1.2mm			
Loading (40HQ)(pcs)	115	93	80	65



Model	S-S41	S-S42	S-S43	S-S44	S-S45	S-S45
Size (L x W x H)	1000*500*800/ 850	1000*600*800/ 850	1200*600*800/ 850	1200*700*800/ 850	1400*700*800/ 850	1500*700*800/ 850
Material	201-304 Grade stainless steel					
Thickness	0.8/1.0mm/1.2mm					
Loading (40HQ)(pcs)	170	140	114	100	75	70

Wash Sink



Model	S-S41	S-S42	S-S43	S-S44	S-S45	S-S45
Size (L x W x H)	1000*500*800/ 850	1000*600*800/ 850	1200*600*800/ 850	1200*700*800/ 850	1400*700*800/ 850	1500*700*800/ 850
Material	201-304 Grade stainless steel					
Thickness	0.8/1.0mm/1.2mm					
Loading (40HQ)(pcs)	170	140	114	100	75	70



Model	ES-S11	ES-S12	ES-S13	ES-S14	ES-S15	ES-S16
Size (L x W x H)	600*600*800/ 850	1000*600*800/ 850	1200*600*800/ 850	700*700*800/ 850	1000*700*800/ 850	1200*700*800/ 850
Material	201-304 Grade stainless steel					
Thickness	0.8/1.0mm/1.2mm					
Loading (40HQ)(pcs)	240	150	120	180	120	105

Wash Sink



Model	ES-S21	ES-S22	ES-S23	ES-S24	ES-S25
Size (L x W x H)	1000*600*800/ 850	1200*600*800/ 850	1200*700*800/ 850	1400*700*800 /850	1500*700*800/ 850
Material	201-304 Grade stainless steel				
Thickness	0.8/1.0mm/1.2mm				
Loading (40HQ)(pcs)	150	120	100	90	84



Model	ES-S31	ES-S32	ES-S33	ES-S24
Size (L x W x H)	1450*600*800/850	1800*600*800/850	1800*700*800/850	2000*700*800/850
Material	201-304 Grade stainless steel			
Thickness	0.8/1.0mm/1.2mm			
Loading (40HQ)(pcs)	150	120	100	90

Wash Sink



Model	ES-S1D1	ES-S1D2	ES-S1D3	ES-S1D4	ES-S1D5
Size (L x W x H)	1000*600*800 /850	1200*600*800 /850	1200*700*800 /850	1400*700*800/ 850	1500*700*800/ 850
Material	201-304 Grade stainless steel				
Thickness	0.8/1.0mm/1.2mm				
Loading (40HQ)(pcs)	150	120	100	90	84



Model	Size (L x W x H)	Material	Thickness	Loading (40HQ)(pcs)
LTS-11	500*500*800/850	201-304 Grade stainless steel	0.8/1.0mm/1.2mm	350
LTS-12	600*600*800/850			250
LTS-13	1000*600*800/850			150
LTS-14	1000*700*800/850			125
LTS-15	1200*600*800/850			120
LTS-16	1200*700*800/850			105
LTS-17	1500*700*800/850			85

Features

The appearance, size and packaging can be customized freely according to your needs.



Model	Size (L x W x H)	Material	Thickness	Loading (40HQ)(pcs)
LTS-21	1000*600*800/850	201-304 Grade stainless steel	0.8/1.0mm/1.2mm	350
LTS-22	1000*700*800/850			250
LTS-23	1200*600*800/850			150
LTS-24	1200*700*800/850			125
LTS-25	1400*700*800/850			120
LTS-26	1500*700*800/850			105



Model	Size (L x W x H)	Material	Thickness	Loading (40HQ)(pcs)
LTS-31	1000*600*800/850	201-304 Grade stainless steel	0.8/1.0mm/1.2mm	350
LTS-32	1000*700*800/850			250
LTS-33	1200*600*800/850			150
LTS-34	1200*700*800/850			125
LTS-35	1400*700*800/850			120
LTS-36	1500*700*800/850			105



Kitchen Stainless Steel Storage Cabinet



Model	WM-1	WM-2	WM-3	WM-4
Size (L x W x H)	1000*400*600	1200*400*600	1500*400*600	1800*400*600
Material	201-304 Grade stainless steel			
Thickness	0.8/1.0mm/1.2mm			
Loading (40HQ)(pcs)	310	260	200	170



CDS-1



CDS-2

Model	Size (L x W x H)	Material	Thickness	Loading (40HQ)(pcs)
CDS-1(2)-1	1500*600*850	201-304 Grade stainless steel	0.8/1.0mm/1.2mm	90
CDS-1(2)-2	1500*700*850			80
CDS-1(2)-3	1600*600*850			90
CDS-1(2)-4	1600*700*850			75
CDS-1(2)-5	1800*600*850			76
CDS-1(2)-6	1800*700*850			70
CDS-1(2)-7	2000*600*850			68
CDS-1(2)-8	2000*700*850			60

Featured Products

Stainless Steel Storage Products

- ODM&OEM
- Price advantage
- Sturdy
- Manufacturer



Kitchen Stainless Steel Storage Cabinet



Model	Size (L x W x H)	Material	Thickness	Loading (40HQ)(pcs)
WTCO-1	1000*600*800/850	201-304 Grade stainless steel	0.8/1.0mm/1.2mm	140
WTCO-2	1200*600*800/850			116
WTCO-3	1500*600*800/850			90
WTCO-4	1800*600*800/850			74
WTCO-5	1000*700*800/850			120
WTCO-6	1200*700*800/850			98
WTCO-7	1400*700*800/850			84
WTCO-8	1500*700*800/850			77
WTCO-9	1500*800*800/850			66
WTCO-10	1800*700*800/850			62
WTCO-11	2000*700*800/850			55
WTCO-12	1800*800*800/850			62



Model	FDSC-1	FDSC-2	FDSC-3
Size (L x W x H)	1000*500*1800	1200*500*1800	1500*500*1800
Material	201-304 Grade stainless steel		
Thickness	0.8/1.0mm/1.2mm		
Loading (40HQ)(pcs)	76	62	48

Stainless Steel Rack



Model	Size (L x W x H)	Packing size(L x W x H)	Material	Thickness	Name	Loading (40HQ)(pcs)
WT00A-1	600*600*800/850	640*640*150	201-304 Grade stainless steel	0.8/1.0mm /1.2mm	Ordinary double layer	1200
WT00A-2	900*600*800/850	940*640*150				820
WT00A-3	1200*600*800/850	1240*640*150				620
WT00A-4	1500*600*800/850	1540*640*150				500
WT00A-5	1800*600*800/850	1840*640*150				420
WT00A-6	1000*700*800/850	1040*740*150				640
WT00A-7	1200*700*800/850	1240*740*150				540
WT00A-8	1500*700*800/850	1540*740*150				430
WT00A-9	1800*700*800/850	1840*740*150				360
WT00A-10	1500*800*800/850	1540*840*150				380
WT00A-11	1800*800*800/850	1840*840*150				320
Customerized Sizes						

Stainless Steel Rack



Model	Size (L x W x H)	Packing size(L x W x H)	Material	Thickness	Name	Loading (40HQ)(pcs)
WT00B-1	600*600*800/850	640*640*210	201-304 Grade stainless steel	0.8/1.0mm /1.2mm	Back Panel	1100
WT00B-2	900*600*800/850	940*640*210				800
WT00B-3	1200*600*800/850	1240*640*210				60
WT00B-4	1500*600*800/850	1540*640*210				480
WT00B-5	1800*600*800/850	1840*640*210				400
WT00B-6	1000*700*800/850	1040*740*210				620
WT00B-7	1200*700*800/850	1240*740*210				500
WT00B-8	1500*700*800/850	1540*740*210				400
WT00B-9	1800*700*800/850	1840*740*210				320
WT00B-10	1500*800*800/850	1540*840*210				350
WT00B-11	1800*800*800/850	1840*840*210				310
Customerized Sizes						

Stainless Steel Rack



Model	Size (L x W x H)	Packing size(L x W x H)	Material	Thickness	Name	Loading (40HQ)(pcs)
WT02A-1	600*600*800/850	640*640*210	201-304 Grade stainless steel	0.8/1.0mm /1.2mm	Double Layer	1100
WT02A-2	900*600*800/850	940*640*210				800
WT02A-3	1200*600*800/850	1240*640*210				60
WT02A-4	1500*600*800/850	1540*640*210				480
WT02A-5	1800*600*800/850	1840*640*210				400
WT02A-6	1000*700*800/850	1040*740*210				620
WT02A-7	1200*700*800/850	1240*740*210				500
WT02A-8	1500*700*800/850	1540*740*210				400
WT02A-9	1800*700*800/850	1840*740*210				320
WT02A-10	1500*800*800/850	1540*840*210				350
WT02A-11	1800*800*800/850	1840*840*210				310
Customerized Sizes						

Stainless Steel Rack



Model	Size (L x W x H)	Packing size(L x W x H)	Material	Thickness	Name	Loading (40HQ)(pcs)
WT02A-1	600*600*800/850	640*640*210	201-304 Grade stainless steel	0.8/1.0mm /1.2mm	Movable assembly version	1100
WT02A-2	900*600*800/850	940*640*210				800
WT02A-3	1200*600*800/850	1240*640*210				60
WT02A-4	1500*600*800/850	1540*640*210				480
WT02A-5	1800*600*800/850	1840*640*210				400
WT02A-6	1000*700*800/850	1040*740*210				620
WT02A-7	1200*700*800/850	1240*740*210				500
WT02A-8	1500*700*800/850	1540*740*210				400
WT02A-9	1800*700*800/850	1840*740*210				320
WT02A-10	1500*800*800/850	1540*840*210				350
WT02A-11	1800*800*800/850	1840*840*210				310
Customerized Sizes						

Stainless Steel Rack



Model	Size (L x W x H)	Packing size(L x W x H)	Material	Thickness	Loading (40HQ)(pcs)
FSSL-1	900*500*1550/1750	900*500*250	201-304 Grade stainless steel	0.8/1.0mm/1.2mm	554
FSSL-2	1000*500*1550/1750	1000*500*250			500
FSSL-3	1200*500*1550/1750	1200*500*250			410
FSSL-4	1500*500*1550/1750	1500*500*250			328
FSSL-5	1800*500*1550/1750	1800*500*250			270



Model	Size (L x W x H)	Packing size(L x W x H)	Material	Thickness	Loading (40HQ)(pcs)
WS1-1	1000*300*300	1000*300*150	201-304 Grade stainless steel	0.8/1.0mm/1.2mm	1258
WS1-2	1200*300*300	1200*300*150			1070
WS1-3	1500*300*300	1500*300*150			830

Stainless Steel Rack



Model	Size (L x W x H)	Packing size(L x W x H)	Material	Thickness	Loading (40HQ)(pcs)
WS2-1	1000*300*300	1000*300*100	201-304 Grade stainless steel	0.8/1.0mm/1.2mm	1658
WS2-2	1200*300*300	1200*300*100			1470
WS2-3	1500*300*300	1500*300*100			1230



Model	Size (L x W x H)	Packing size(L x W x H)	Material	Thickness	Loading (40HQ)(pcs)
WS2-1	1000*300*300	1000*300*100	201-304 Grade stainless steel	0.8/1.0mm/1.2mm	1658
WS2-2	1200*300*300	1200*300*100			1470
WS2-3	1500*300*300	1500*300*100			1230



Model	Size (L x W x H)	Packing size(L x W x H)	Material	Thickness	Loading (40HQ)(pcs)
WSR-1	1000*300*300	1000*300*150	201-304 Grade stainless steel	0.8/1.0mm/1.2mm	1258
WSR-2	1200*300*300	1200*300*150			1070
WSR-3	1500*300*300	1500*300*150			830

Stainless Steel Rack



Model	Size (L x W x H)	Packing size(L x W x H)	Material	Thickness	Loading (40HQ)(pcs)
2WS1-1	1000*300*700	1000*300*300	201-304 Grade stainless steel	0.8/1.0mm/1.2mm	830
2WS1-2	1200*300*700	1200*300*300			700
2WS1-3	1500*300*700	1500*300*300			554

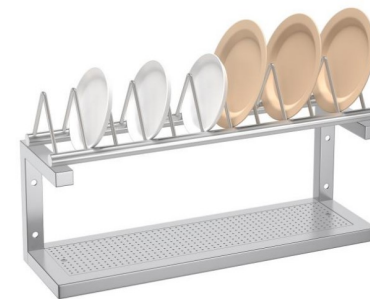

Model	Size (L x W x H)	Packing size(L x W x H)	Material	Thickness	Loading (40HQ)(pcs)
XWC1-1	600*300*450	600*300*150	201-304 Grade stainless steel	0.8/1.0mm/1.2mm	2800
XWC1-2	900*300*450	900*300*150			1860
XWC1-3	1000*300*450	1000*300*150			1680
XWC1-4	1200*300*450	1200*300*150			1400
XWC1-5	1500*300*450	1500*300*150			1050

Stainless Steel Rack

Features

The appearance, size and packaging can be customized freely according to your needs.



Trolley

Model	ZZJYGZ-1	ZZJYGZ-2
Size (L x W x H)	(1000-2000)*700*850	(1000-2000)*600*850
Thickness	0.8-1.2	0.8-1.2
Loading (40HQ)(pcs)	127	110
Material	201/304 Grade stainless steel	



Model	KINGBETTER
Size (L x W x H)	600*900*850
Packing size(L x W x H)	650*950*300
Thickness	0.8-1.2
Loading (40HQ)(pcs)	420
Material	201/304 Grade stainless steel

Model	TLTO3
Size (L x W x H)	(800-1200)*500*940
Packing size(L x W x H)	(940-1200)*500*3.00
Thickness	0.8-1.2
Loading (40HQ)(pcs)	500-3.00
Material	201/304 Grade stainless steel



Model	DPC-30G
Size (L x W x H)	550*745*1735
Thickness	0.8-1.2
Loading (40HQ)(pcs)	230
Material	201/304 Grade stainless steel

Innovation

Products

Commercial Range Hood

- ODM&OEM
- Price advantage
- Environmental friendly
- Manufacturer



Model	BXGYZA-1	BXGYZA-2	BXGYZA-3
Size (L x W x H)	1500*800*400	1800*800*400	2000*800*400
Thickness	0.8-1.2	0.8-1.2	0.8-1.2
Loading (40HQ)(pcs)	150	120	110
Material	201/304 Grade stainless steel		

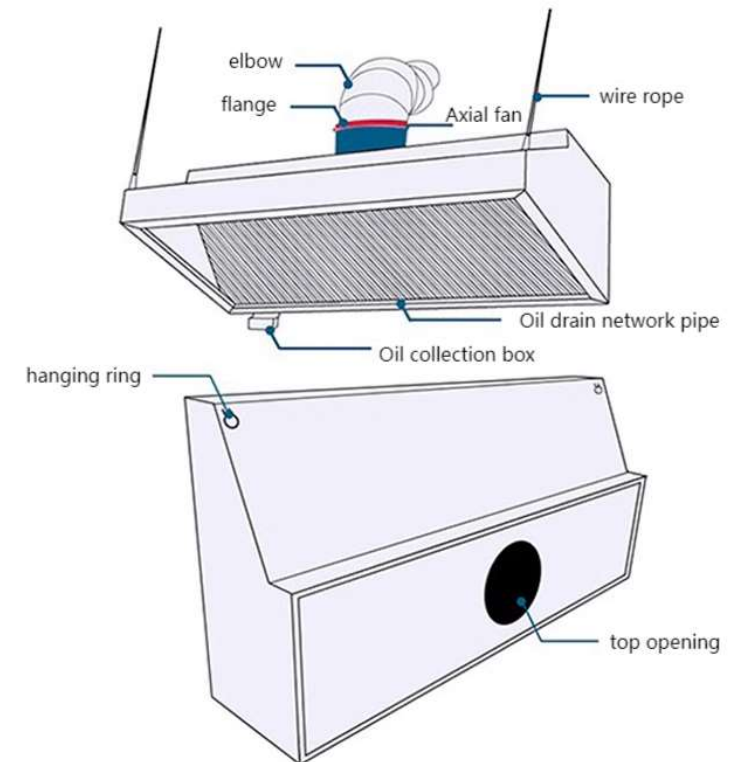

Commercial Range Hood



Model	Size (L x W x H)	Material	Purification rate	Voltage (V)	Power(W)	Loading (40HQ)(pcs)
YTJYZ-1	1000*1040*1000	201/304 Grade stainless steel	98%	220V	800	70
YTJYZ-2	1200*1040*1000				1000	60
YTJYZ-3	1500*1040*1000				1300	45
YTJYZ-4	1800*1040*1000				1800	40
YTJYZ-5	2000*1040*1000				1800	36
YTJYZ-6	2500*1040*1000				2600	28
YTJYZ-7	3000*1040*1000				3000	24

Environmental protection function;

Energy saving and low consumption, high frequency self-cleaning, adsorption purification.

Commercial Range Hood



Model	Size (L x W x H)	Material	Motor Quantity	Voltage (V)	Power(W)	Loading (40HQ)(pcs)
YZDYZ-1	600*600*500	201/304 Grade stainless steel	1	220V	680/880	400
YTJYZ-2	800*600*500					310
YTJYZ-3	1000*600*500					250
YTJYZ-4	1000*800*500					190
YTJYZ-5	1200*600*500					210
YTJYZ-6	1200*800*500					150
YTJYZ-7	1500*600*500					160
YTJYZ-8	1500*800*500					120



Model	Size (L x W x H)	Material	Motor Quantity	Voltage (V)	Power(W)	Loading (40HQ)(pcs)
YZDST-1	1500*800*500	201/304 Grade stainless steel	1	220V	680/880	120
YZDST-2	1800*800*500					100
YZDST-3	2000*800*500					95
YZDST-4	2200*800*500					86
YZDST-5	2500*800*500					76
YZDST-6	3000*800*500					60

Size Customization